

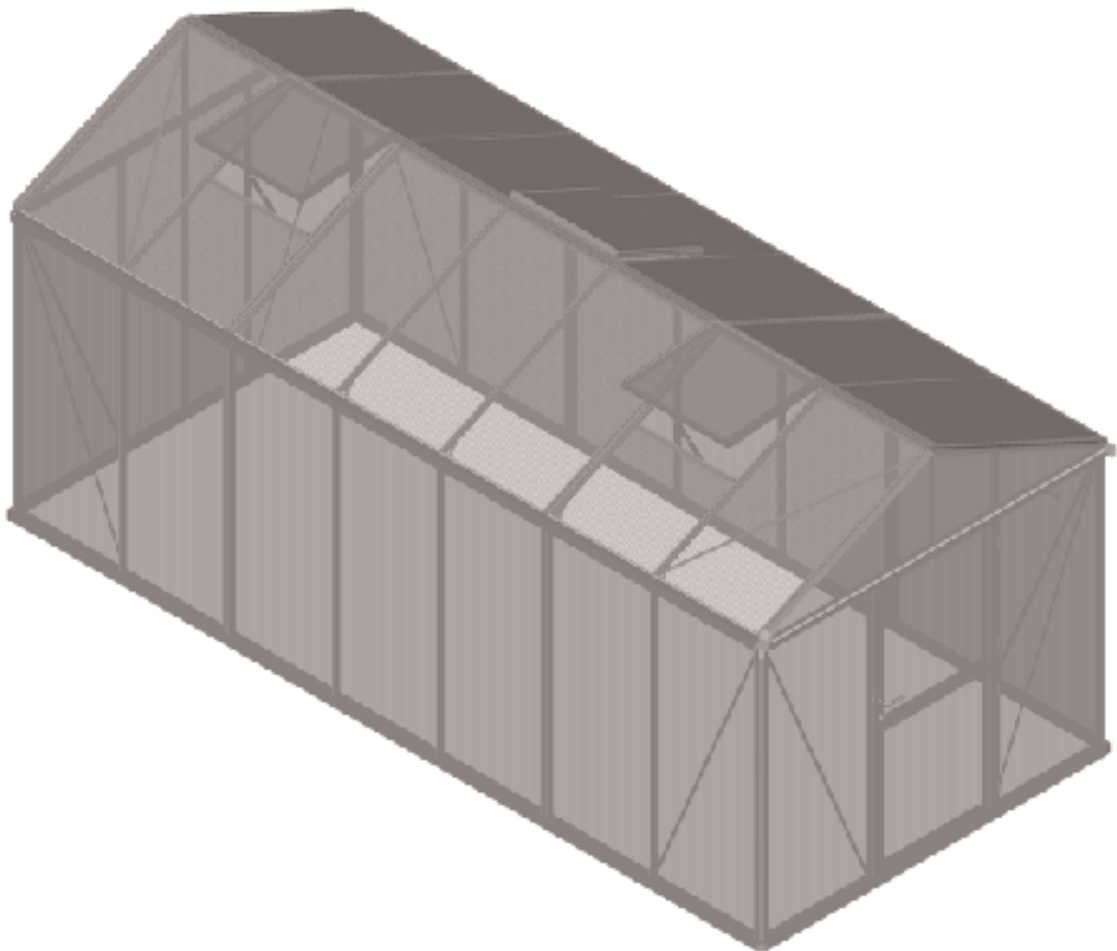

Instructions for assembly and use of the Optimum models 115 & 135 Greenhouse



1 Safety Precautions

1. PLEASE READ THESE ENTIRE ASSEMBLY INSTRUCTIONS BEFORE STARTING TO ERECT THE GREENHOUSE!
2. You should always wear gloves when handling the polycarbonate panels. The sharp edges can cause injuries. Sharp edges or corners of the aluminium profile sections can also cause injuries, so always wear gloves with them, too!
3. The product you have purchased is intended for growing plants, and should be used for that purpose only. We decline all liability in case of other usage.
4. Two people are needed to assemble this product.

Site selection

Select the sunniest spot that is also sheltered from the wind for your greenhouse. The selection of the site is extremely important for success in growing and for the safety of your greenhouse!

Before you begin

Important: Before beginning with the assembly, check whether all the parts listed in the parts list are present. To do this, take the individual packs out of the packaging. Be careful not to mix up the packs, which are numbered according to the steps in assembly. When you have set out the packs separately, open them in order to identify the individual parts more easily.

It is important not to mix up the opened packs!

If parts are missing, contact your stockist and inform them of the quantity and parts numbers of the missing parts. You will find the parts numbers on the parts list on pages 4-6. If it should happen that a part appears not to fit, do not start drilling or sawing it. Contact your supplier, and inform them. The customer-service section responsible for you will get in touch with you.

The greenhouse should be washed thoroughly with a mild detergent from time to time. It is important to use a detergent that will not attack the UV layer of the polycarbonate panels, the covering sections, or the aluminium frame.

In case of snowfall, the snow must be cleared off the roof promptly—in particular, before it starts to thaw—because a large weight of snow can damage the greenhouse or make it unsafe. In case of heavy snowfalls, the roof must be cleared as soon as possible.

In strong winds, all openings (vents and doors) should be closed, since otherwise this presents a larger area to the wind.

Tools needed

1. A screwdriver (plain and Phillips)
2. A spanner or socket spanner (10 mm)
3. A rubber hammer
4. A ladder
5. A spirit level
6. An electric drill or battery-powered screwdriver with a 2-mm metal-drilling bit

REMARKS

For full protection of the greenhouse and as a general precaution, we recommend including the greenhouse in your homeowner's insurance. Contact your insurance agent for this purpose. Check any local building regulations that may apply.

Follow the instructions and notes in this manual exactly, and you will not have any difficulty with the assembly. If you find any supposed mistakes in these instruction, or if some passage is unclear, contact your stockist.

3 Foundation

In order to erect the Optimum greenhouse, you need a fixed base. This base (the foundation) can be made from concrete or bricks. If you do not have any experience in foundation work, please have it done by a specialist.

Build a frost-resistant base to the dimensions given in the table. Be careful to match the dimensions of the frame given in the table. Note that angle brackets will have to be mounted on the inside of the frame later, in order to fasten it.

IMPORTANT: The foundation must be precisely horizontal and rectangular! Please use a spirit level and a set square to check this.

After completing the base, place the completely assembled greenhouse frame onto the foundation. Glaze the greenhouse completely, and install the doors and vents.

Do not connect the foundation and the ground frame until everything is aligned at right angles and completely assembled.

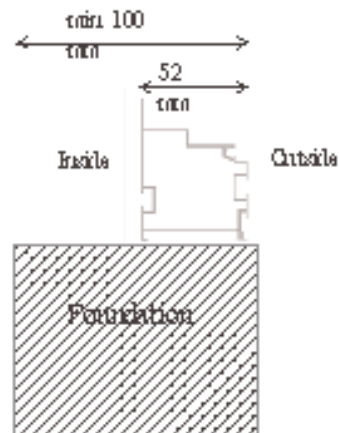
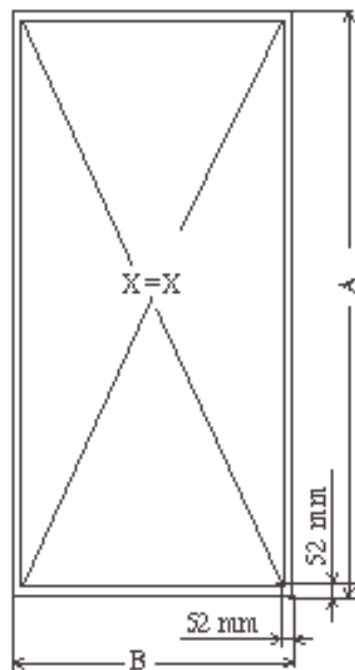

IMPORTANT: None of the materials needed to prepare the foundation or the tools are included as part of the kit.































	Length (mm) A	Width (mm) B
Optimum 78	3120	2500
Optimum 96	3860	2500
Optimum 115	4690	2500
Optimum 135	5370	2500

Parts List

4

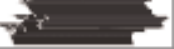
Item no.	Illustration	Description	Size (mm)	Quantity (in 115)	Quantity (in 135)	Erection Step
22524		Hex-head screw	M6 x 12	201	201	1-13
22601		Washer	6,5	32	32	3
22602		Machine screw	M5 x 16	8	8	6
22525		Machine screw	M6 x 10	32	32	3
22526		Countersunk machine screw	M5 x 30	1	1	11
22597		Sheet-metal screw	4,8x9,5	2	2	11
22527		Sheet-metal screw	4,2x9,5	4	4	11/13
22528		Countersunk screw	4,2x9,5	28	28	11/13
22598		Self-tapping screw	4,2x13	7	7	11
22529		Countersunk screw	4,8x13	4	4	11
22530		Sheet-metal screw	4,8x22	10	10	10
22531		Sheet-metal screw	4,8x25	8	8	11
22599		Parker screw	M6 x 60	16	16	Foundation
00136		Tee-head bolt	M6 x 12	30	30	9
22532		Nut & lock-ring	M6	201	217	1-13
22600		Washer	6,4x18	201	217	1-13
22538		Keyhole plate	-	2	2	11
22537		Door-frame lock	-	1	1	11
22594		Door connecting latch	-	1	1	11
22534		Door-handle surround	-	2	2	11
22535		Latch pin	-	1	1	11
22536		Door bolt	-	1	1	11
22539		Cylinder lock	-	1	1	11
22503		Hinge	-	4	4	13
22520		Plastic corner	-	4	4	1
00450		Vent lifter	-	2	2	14
22541		Door stop	-	1	1	13
15131		Bracket / Vent Stay	-	3	3	14
00451-21		Peg - Vent	-	6	6	14

5 Parts List (2)

Item no.	Illustration	Description	Size (mm)	Quantity (in115)	Quantity (in135)	Erection Step
22.596		Dowel plug	10 x 50	16	16	Foundation
22.521		Gutter corner cap, right	-	2	2	15
22.522		Gutter corner cap, left	-	2	2	15
22.523		Ridge cap	-	2	2	15
22130		Floor section, short	1508	6	4	1
22131		Floor section, long	2245	-	2	1
22132		Floor section, front & rear	2393	2	2	1
22140		Gutter section, short	1508	6	4	3
22141		Gutter section, long	2245	-	2	3
22010		Intermediate section	1780	9	11	5
22091		Door rabbet, lock	1780	1	1	5
22011		Roof intermediate section	1310	6	8	7
22210		Connecting Plate Internal	117	10	10	1 / 3 / 6
22110		Gable corner section	1310	4	4	6
22020		Corner side section	1780	4	4	2
22090		Door rabbet, hinge	1780	1	1	5
22012		Gable section, vertical	567	2	2	6
22120		Cross brace, front & rear	2393	2	2	4
22030		Side central section	1780	4	4	2
22031		Roof central section	1310	4	4	7
22.501		Gutter corner plate	-	4	4	7
22.500		Ridge corner plate	-	4	4	7
22154		Door rebate, centre	863	1	1	12
22100		Ridge section, short	1508	3	2	6
22101		Ridge section, long	2245	-	1	6
22153		Side angle-piece	-	6	8	7
22152		Roof angle-piece	-	3	4	7
22150		Diagonal brace, roof	1512	4	4	8
15134		Bracket - Door	-	4	4	11

Parts List (3)

6

Item no.	Illustration	Description	Size(mm)	Quantity (in115)	Quantity (in135)	Erection Step
22151		Diagonal brace, side	1934	8	8	8
22160		Inside angle-piece	-	4	4	1
15079		Plate - Vent Peg	-	6	6	14
22060		Window-sill	771	3	3	9
22061		Vent section, side	658	6	6	9
22070		Vent section, top	750	3	3	9
22050		Vent section, bottom	750	3	3	9
22043		Door section, side	658	3	3	10
22042		Door section, lock	1780	1	1	10
22080		Door section, top & bottom	849	4	4	10
22300		Connecting Plate External	117	8	8	1 / 3
22545		Door handles & cotter pin	-	1	1	10
22200		Ridge joining piece	140	4	4	6
22595		Foundation angle-piece	100	8	8	Foundation
22562		Rubber Section 6mm & Glass	1780	8	8	9/11
22563		Rubber section, 10 mm	1780	8	8	9/11
22564		Centre cap, 6 & 10 mm	1785	9	11	12
22585		Centre cap, 6 & 10 mm	1320	6	8	12
22566		Centre cap, 6 & 10 mm	570	2	2	12
22582/186/170		Corner cap, 6 & 10 mm	1320	16	16	12
22571		Corner cap, 6 & 10 mm	1785	18	18	12
22567		Centre cap, 16 mm	570	2	2	12
22584		Centre cap, 16 mm	1320	6	8	12
22569		Centre cap, 16 mm	1785	9	11	12
22583/187/172		Corner cap, 16 mm	1320	16	16	12
22573		Corner cap, 16 mm	1785	18	18	12
22574	See Door Handle	Vent seal, rubber	3000	3	3	9
15061		"O" Section	-	100	100	12
15133		Horizontal Brace	752	2	2	5

7 Assembly Step 1

(Ground Frame)

Take the aluminium box sections out of Pack 1, and lay them out on the ground as shown in Fig. 1A. Take the four side sections, according to the model, and connect them as shown in Fig. 1B, by means of the connection plates 22210. Then connect the ground sections with the rounded-off corner connection pieces 22520 & 22300. As shown in Fig. 1C, insert a loose screw into each of the sections, and then, after the sections have been inserted into the plastic corner piece, fix the corner piece in position by means of angle-piece 22160.

Check whether the sections are at right angles to one another. Do not screw down the frame onto the foundation until the greenhouse has been completely assembled (including glazing).

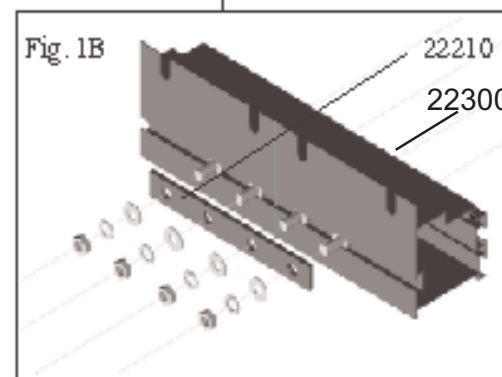
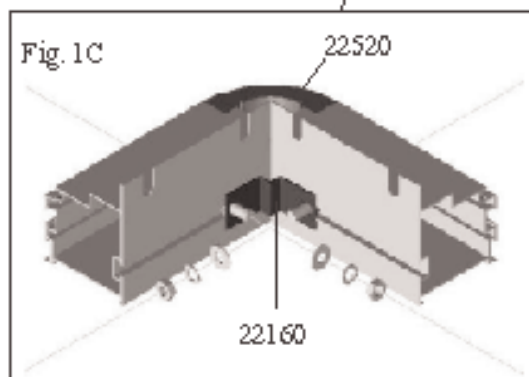
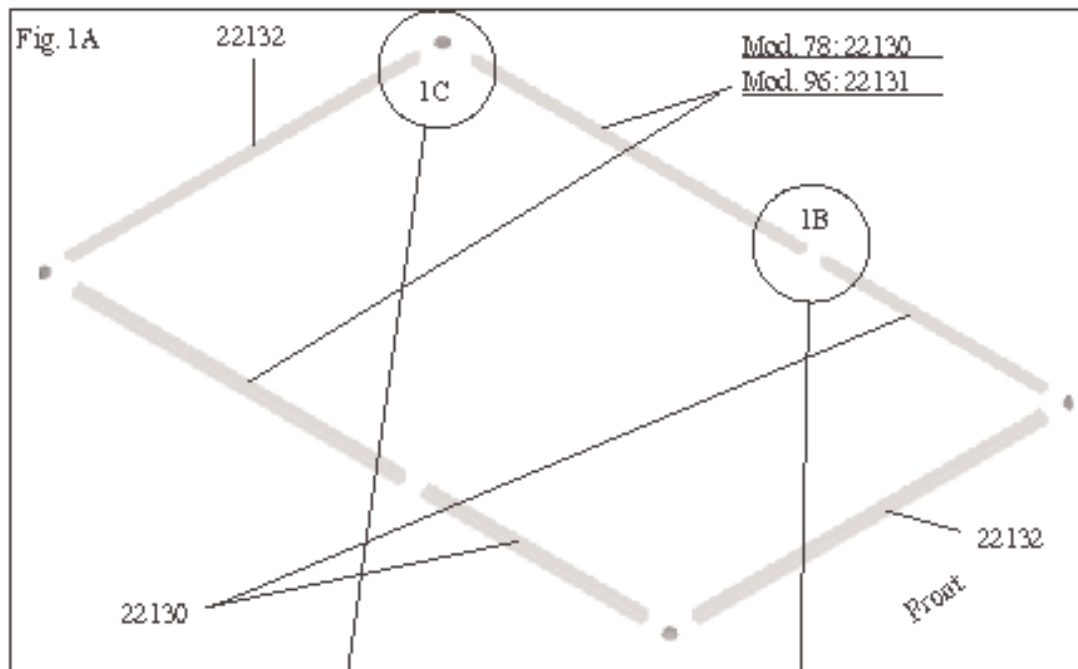

Important: Check the lengths carefully, according to the item numbers of the sections, in order to avoid mistakes at this point! (The short side sections are mounted in the front door area — see illustration.)

The hexagon-head screws are made of aluminium, which is a soft metal. You should acquire a feeling for how firmly one may tighten the screws.

Assembly Step 2

(Vertical Sections)

8

Now take the corner sections 22020, and insert a screw (M 6 x 12) from each side (top and bottom) into the two guide rails. Screw them down hand-tight at a distance of about 5 cm from the edge.

Now place the corner sections on the corners of the ground frame, and loosen the lightly tightened screws. Slide the screws into the notches of the ground frame, and tighten them down (see Fig. 2A).

Do the same thing with the central side section 22030. Once again, fasten the four screws loosely at the top and bottom of the screw channel of the central pillar, and then place the latter at the position where the ground side rails abut one another, and screw it to the ground frame (Fig. 2B).

Insert two loose screws from above into the first screw channel from the front of each central section. You will need these loose screws at a later point, when the gutter corner plates need to be installed (assembly step 7).

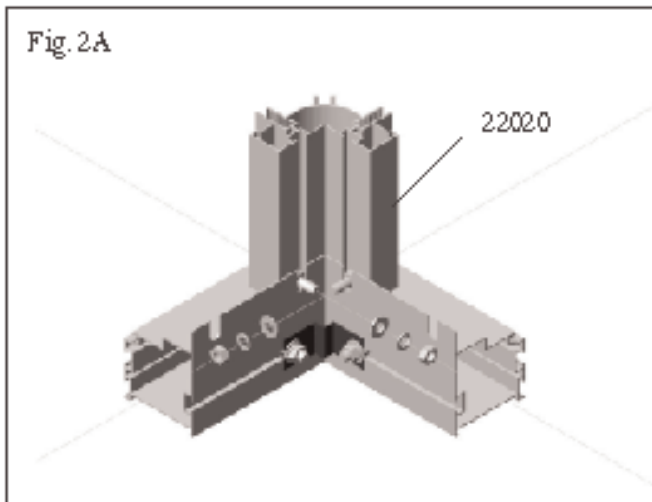

Important: Be careful not to let the channel sections fall over, since this might damage the material!

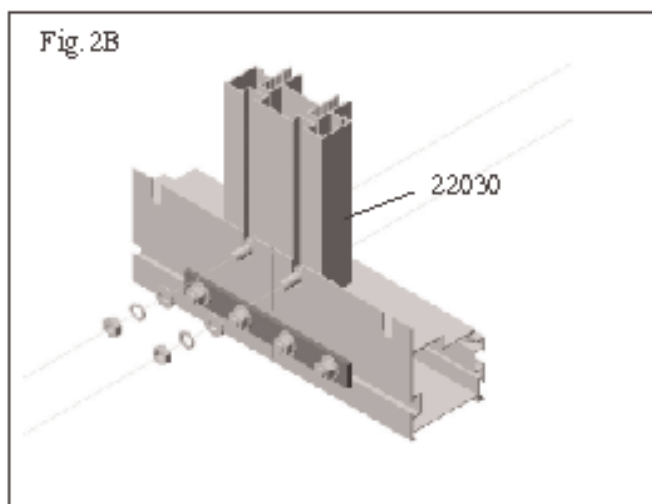

All side sections are 1780 mm long.

All the nuts are on the inside of the greenhouse.

All the detail drawings, unless otherwise marked, are interior views.

9 Assembly Step 3

(Gutter Sections)

Now install the profile-section gutters. Take the sections that match your model (see Fig. 3C), and connect them by means of the connecting pieces 22210 (inside, see Fig. 3A) and 22300 (outside, see Fig. 3B).

Next, lay them on the vertical sections as shown in Fig. 3C; unscrew the loosely tightened screw, and slide them into the notches in the gutters, and then tighten them firmly.

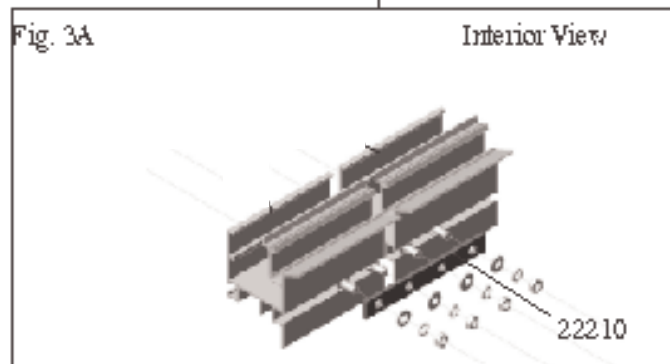
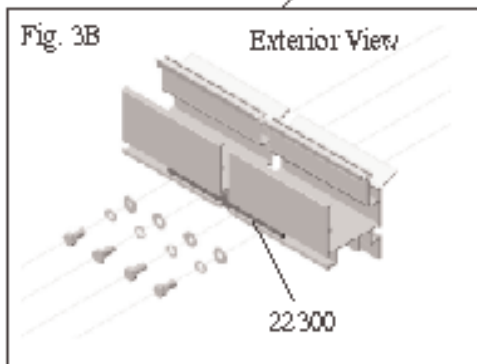
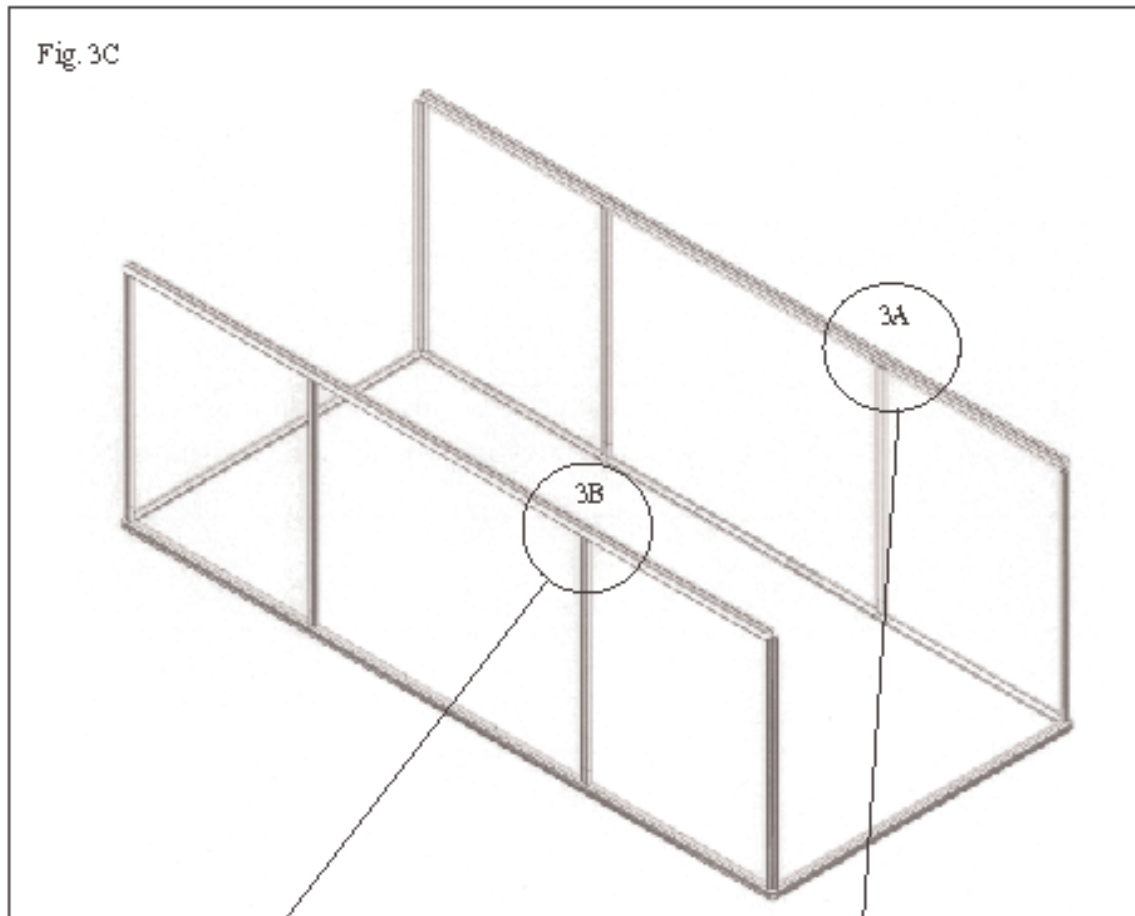

Important: You should have an assistant at this point, who will hold the structure until the gutter sections have been screwed down.

Assembly Step 4

(Front & Rear Rails)

10

Proceed in exactly the same way as for the gutters, and screw the sections 22120 to the corner sections at the front and rear ends (see Figs. 4A and 4B).

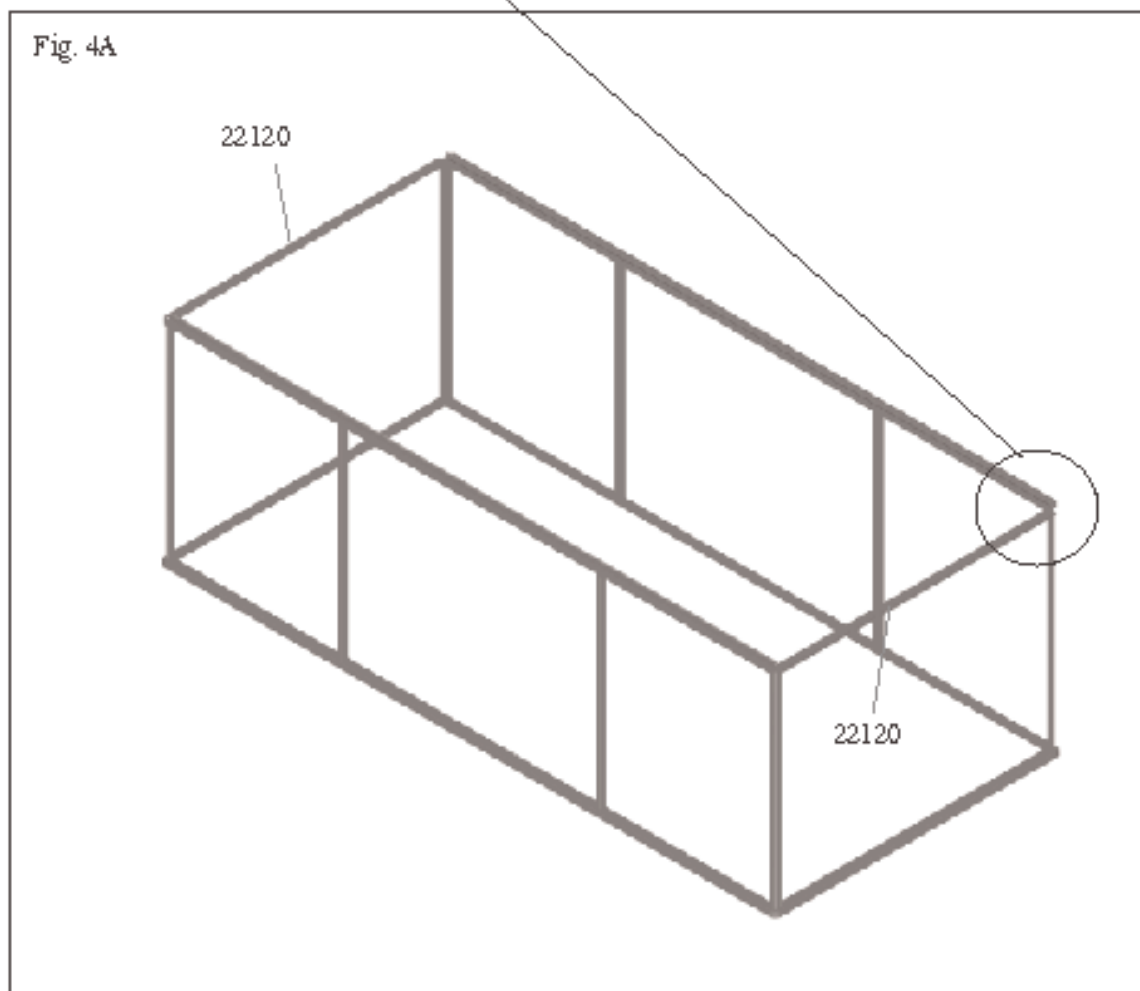
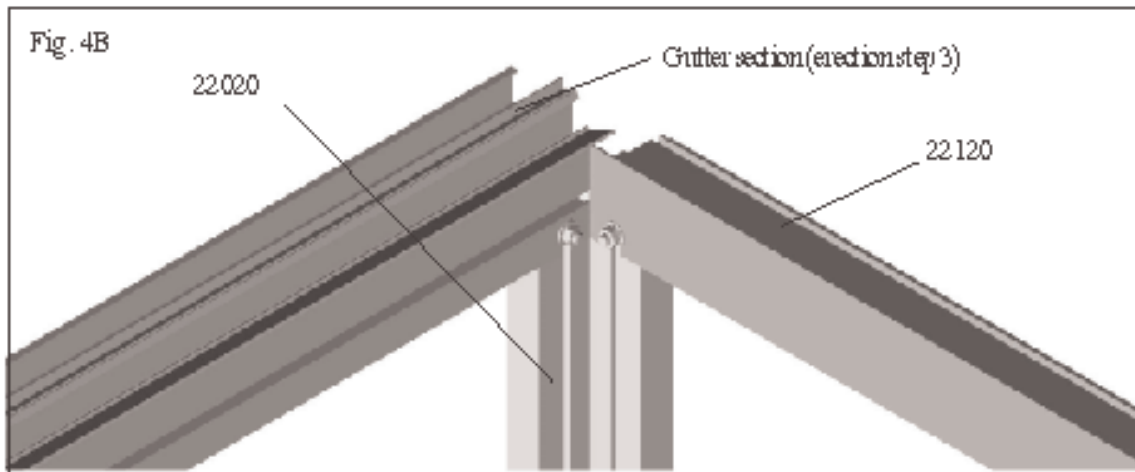

11 Assembly Step 5

(Intermediate Sections)

Now take the sections 22010, and insert them like the central side sections between the gutter and the ground frame (Fig. 5A).

IMPORTANT: You must insert a loose screw, which will be required at a later stage, into each section 22010 (see Fig. 5B).

Do the same on the rear; however, here you do not need to insert loose screws (Fig. 5C).

NOTE: In the rear area, the two central glazing panels are narrower than in the side walls.

Now take the two door-frame sections, and once again insert a loose screw at top and bottom.

Now fasten the door frame with the notch for the lock (22091) in the usual fashion at the left side, as seen from in front of the greenhouse, and the frame with the holes for the hinges (22090) on the right side (Fig. 5D). Front view: Fig. 5C

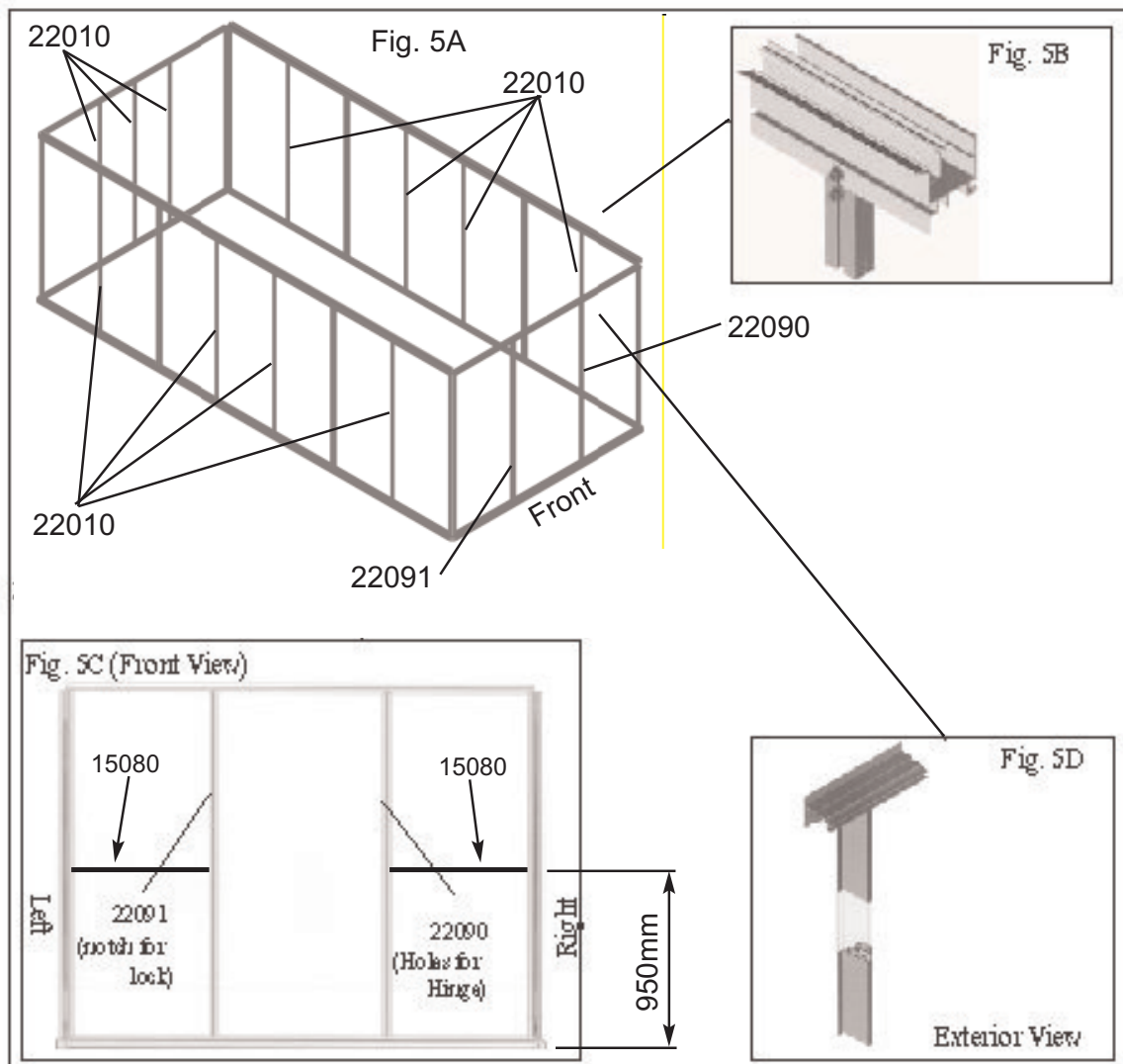

Assembly Step 6 (Ridge & Gable Sections)

12

Now assemble the roof ridge. To do this, take the sections matching your model (see Fig. 6a), and connect them with the connecting pieces 22210 (from below – see Fig. 6B and 6C), and with the connecting pieces 22200 (from both sides of the section – see Fig. 6B and 6C). Set the ridge aside for the moment.

Now assemble the gable sections 22110, the vertical roof support 22012, and the ridge by means of the connecting plate 22500, as shown in Fig. 6D.

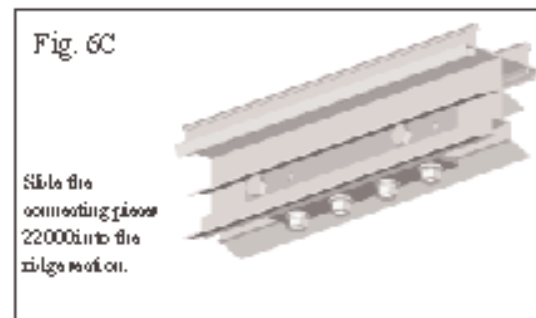
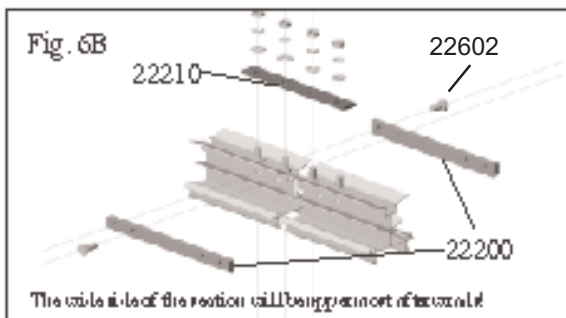

Note: When inserting the gable, be careful not to try to force the four sections and the connecting plate together! Do not tighten down the screws all the way at first, but leave a little play, so that you can slide the sections to and fro carefully. Do not tighten down all the screws until all the sections are inserted into one another and at right angles.

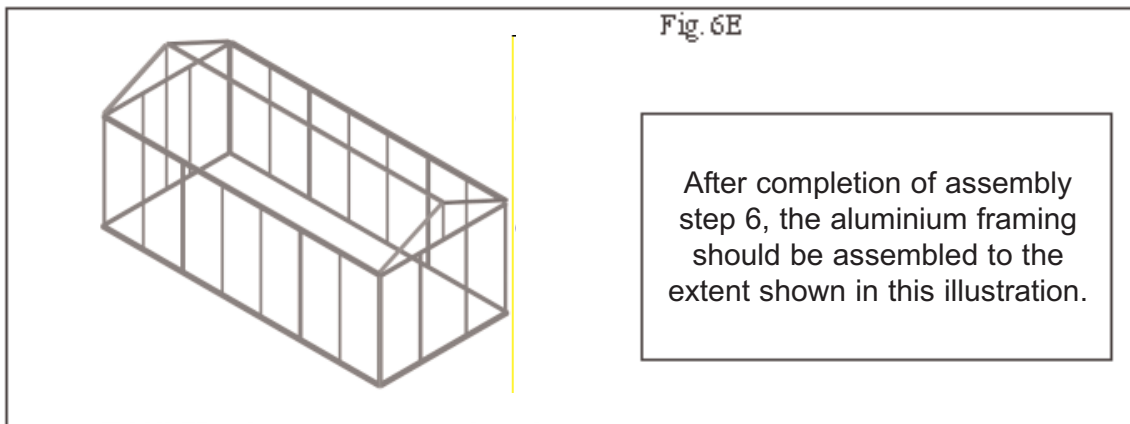
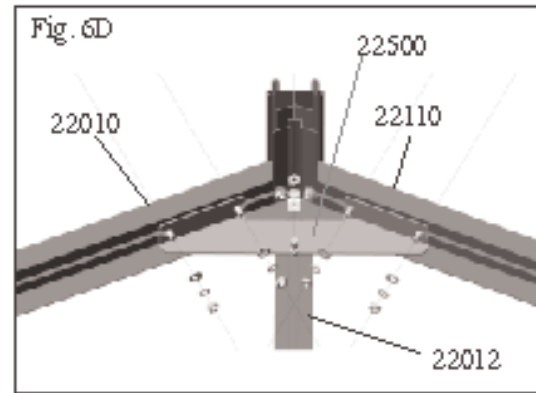

13 Assembly Step 7

(Intermediate Sections)

In the same way as in assembly steps 2 and 5, connect the ridge and gutters with central (22031) and intermediate (22011) roof sections (see Fig. 7A for the central section, Fig. 7B for the intermediate section).

Before screwing the sections tightly to the ridge or gutter, insert the four loose screws (two screws per screw channel) for each central roof section 22031 (see Fig. 7A), and two screws per intermediate roof section 22011 (see Fig. 7B) which will be needed for the stiffening angle-pieces (22501, 22500, 22152, and 22153). You already slid the loose screws into the central and intermediate side sections in Step 2 and 5.

Screw the respective angle-piece 22501, gutter connecting plate (7§), ridge connecting plate 22500 (7C), gutter angle brace 22153 (7F) and ridge angle brace 22152 (7E) to the gutter or ridge as shown.

Caution: At the positions where you plan to install the roof vents, one more bolt must be included on the left and on the right!

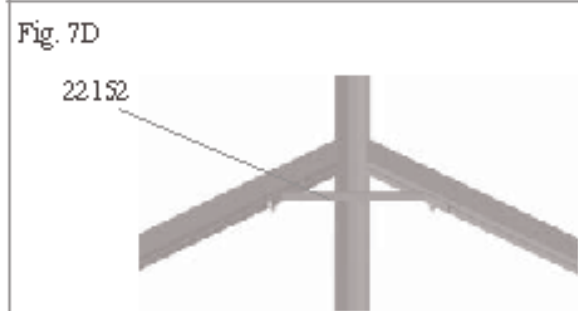
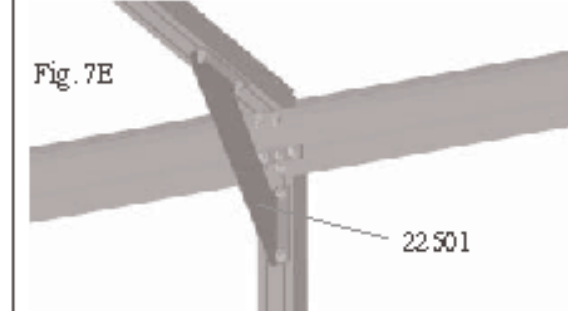
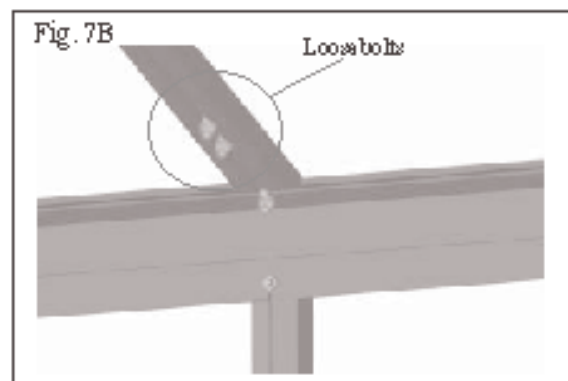
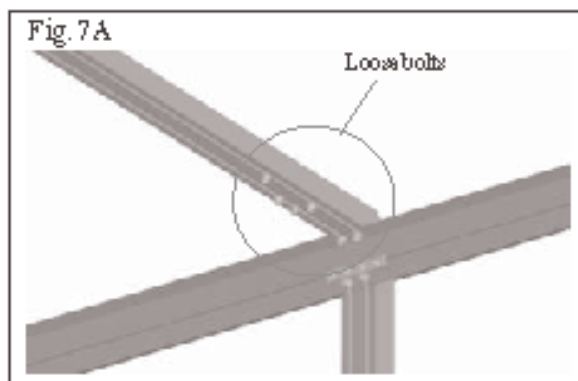

Now take the diagonal braces 22151 for the side walls, and 22150 for the roof structure. These diagonal braces are inserted in the first and last panels and on the front and rear as stiffeners, as shown in Fig. 8A.

To do this, unscrew, as shown in Fig. 8B, the screws of the vertical braces (side walls and roof) that have already been tightened, and tighten them down again once the diagonal braces have been placed.

If the diagonal braces do not fit, your greenhouse is not properly rectangular!

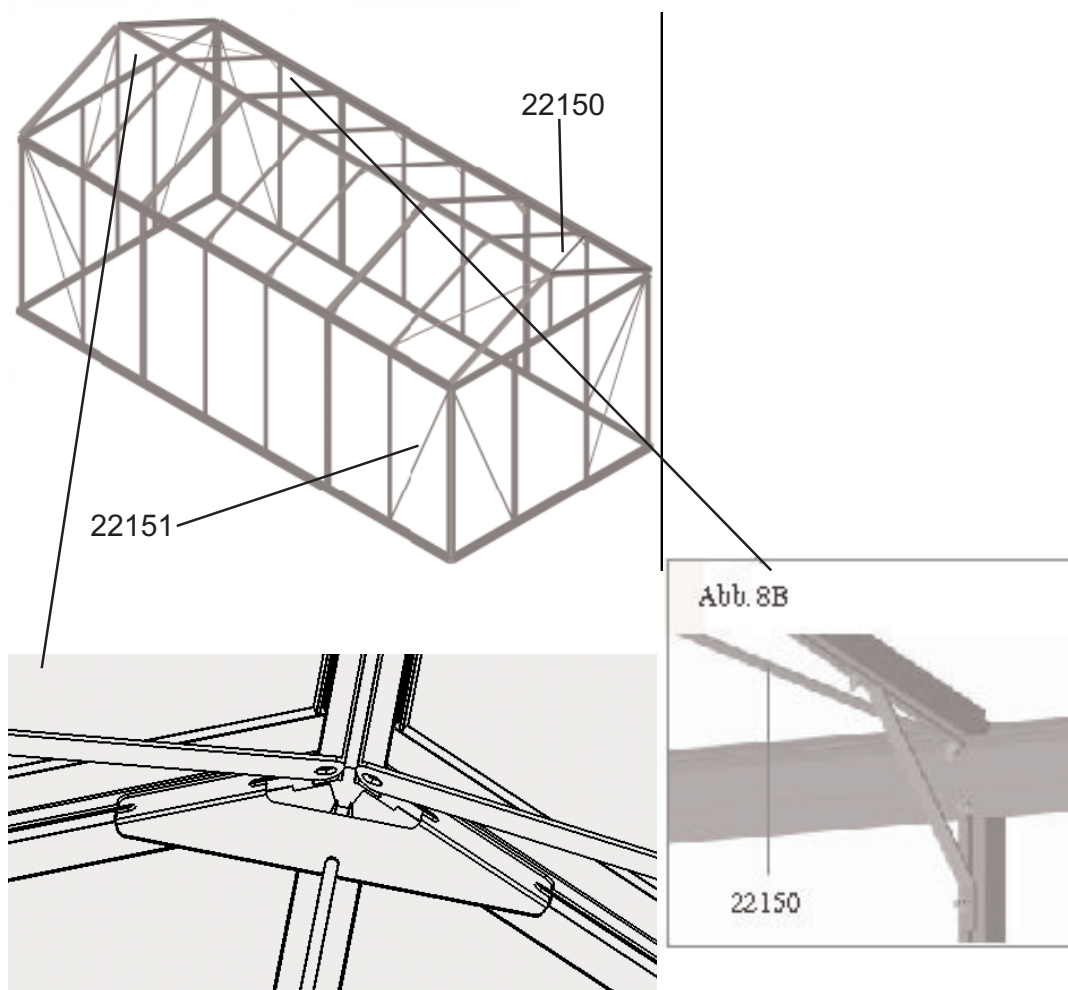

Tip: You can slacken the whole structure a bit by loosening individual screws in the corners. Once all the slots of the diagonal braces are centred on the screws, tighten up all the screws again. As a final check, insert a double-glazed pane into each of the four outer roof panels. If these sit in parallel in the respective frames, the greenhouse is properly rectangular.

15 Assembly Step 9

(Preparation of Roof Vent)

In order to prepare for installation of the roof vents, the window-sill sections 22060 must be installed in the correct segment (see Note). The section with parts number 22060 is needed in order to fasten the vent stay. For this purpose, insert two loose screws into 22060 at this point.

Place the two sections (22060), the tee-head bolts (M 6 x 12/ 00136) supplied, and the double-glazed pane 369.543.6 (6 mm), 369.553.6 (10 mm) or 369.563.6 (16 mm) at hand.

Now slide the U section 22590 (6 mm), 22592 (10 mm) or 22593 (16 mm) onto the double-glazed pane, and place the latter in the roof panel where you intend to install the roof vent later (Fig. 9A).

Note: The roof vents cannot be installed in the frontmost or rearmost roof panels, since the diagonal braces will run over these later. Nor is it possible to install the vents next to one another! The best arrangement is on a diagonal, on opposite sides (see Fig. 9B).

Screw the tee-head bolts 136 a half-turn clockwise into the intermediate roof section; slide section 22060 onto their thread, and then screw on the nuts a whole turn.

Now slide section 22060 on over the double-glazed pane, which has been inserted from above (Fig. 9C). Next, slide the rubber section (22562 for the 6-mm pane, or 22563 for the 10-mm pane) between the aluminium frame and the double-glazed pane, as shown in Fig. 9C. (First, you will have to cut off 725 mm of the seal, since this is needed in another place.)

Once the section is seated on the double-glazed pane, tighten the two tee-head bolts.

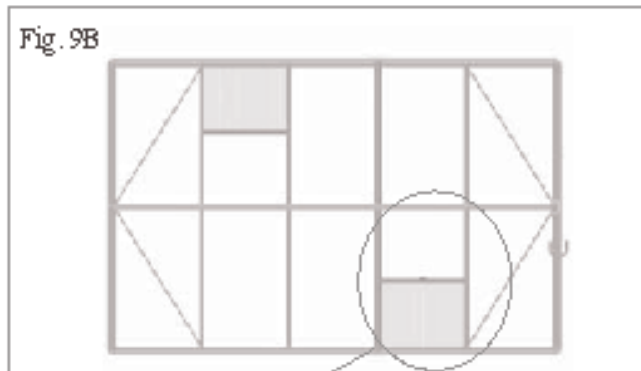
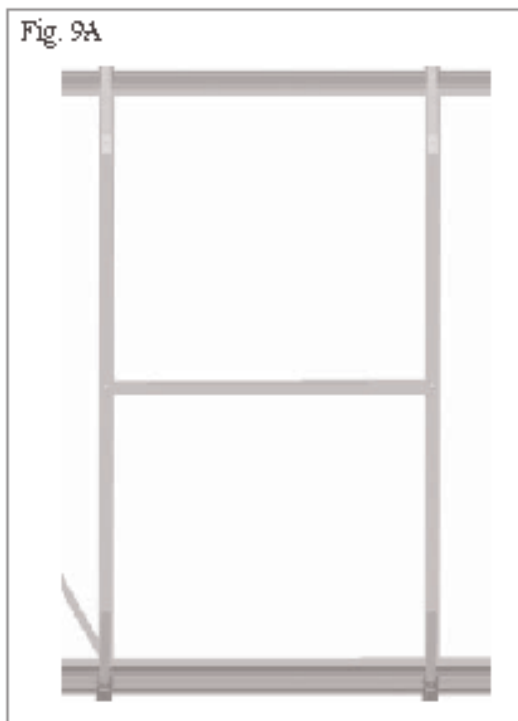

Assembly Step 10

(Roof Vents)

16

Now install two roof vents. The procedure is identical for both vents. To install one vent, proceed as follows. Then install the second one in exactly the same way.

Take the sections 22050, 22061 (two pieces), and 22070. Using two sheet-metal screws 22530 (4.8 x 22 mm), screw the two side sections (22061) to the right and left ends of the upper vent section (22070) – see Fig. 10A.

Draw the vent seal (22574) into the respective notches of the four vent sections, as shown in Fig. 10B.

Now take the double-glazed pane 369.542.6 (6 mm), 369.552.6 (10 mm), or 369.562.6 (16 mm), and the matching U section 22576 (6 mm), 22575 (10 mm), or 22577 (16 mm), (none for glass) and slide this onto the bottom end of the double-glazed pane (see Fig. 10C).

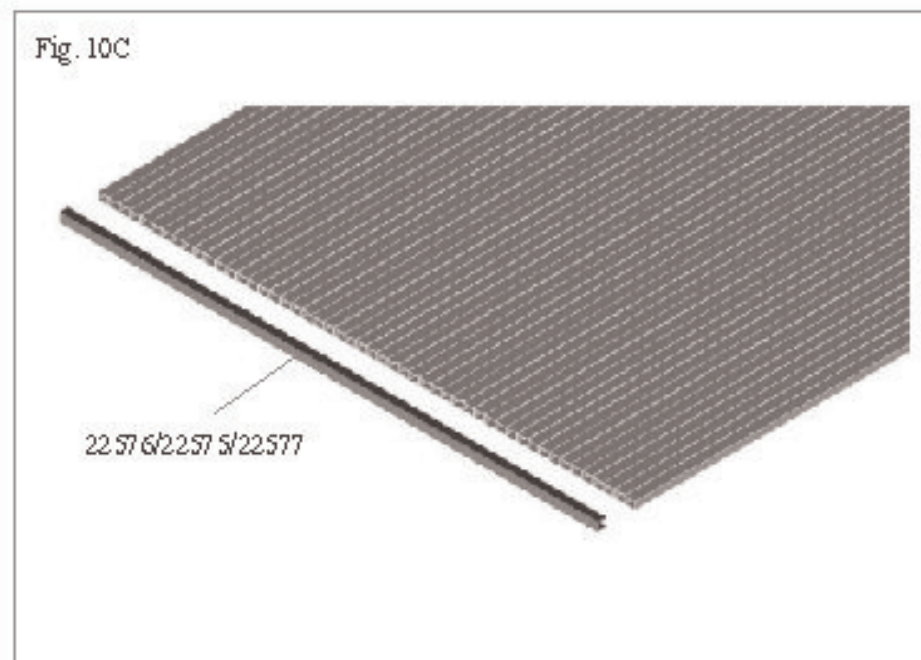
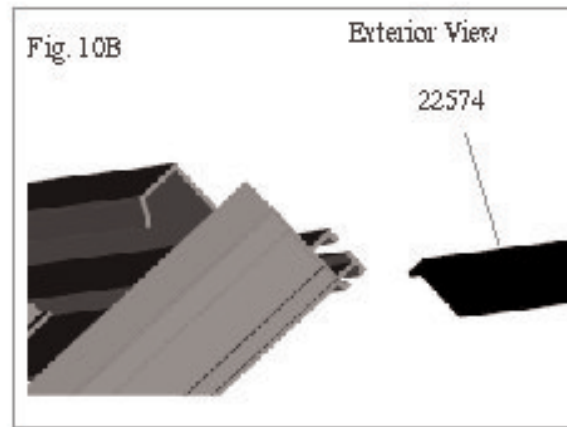
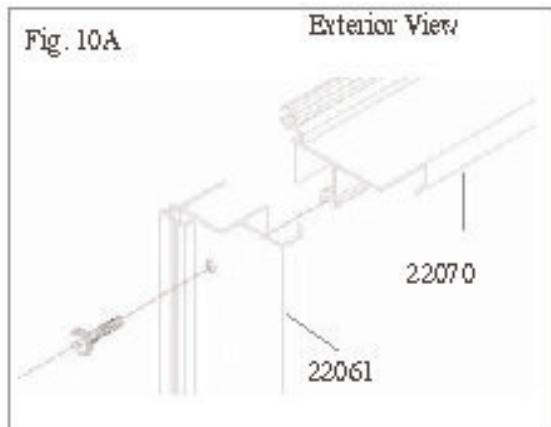

17 Assembly Step 10

(Roof Vents (2))

Slide the prepared double-glazed pane into the prepared U structure assembled above (see Fig. 10D), and screw down the section (22050) as shown in Fig. 10D, in order to close the vent frame. But first insert two loose hex-head 6 x 12 mm screws into the section. These screws will be needed later for installing the vent stay. Depending on the thickness of the double-glazed pane (for 6 or 10 mm), slide the rubber profile supplied (22562 for 6 mm, or 22563 for 10 mm) between the section and the double-glazed pane on what will later be the outer side, as shown in Fig. 10F. Ensure double sided foam is applied to underside edges of glass as shown in fig 10G.

After assembling the two vents, set them aside for the moment.

Note: For a 16-mm thick double-glazed pane, no rubber seal is used at this location.

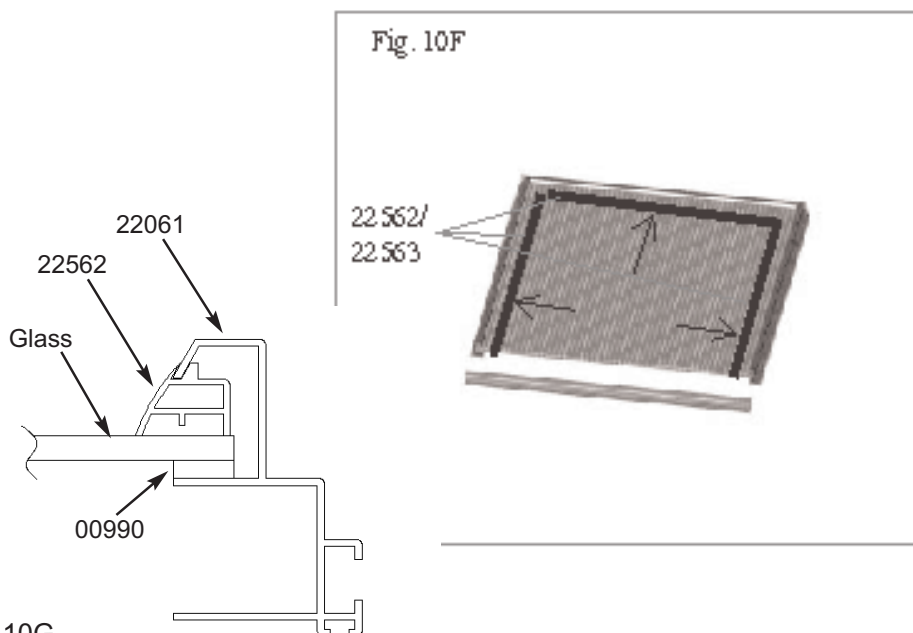
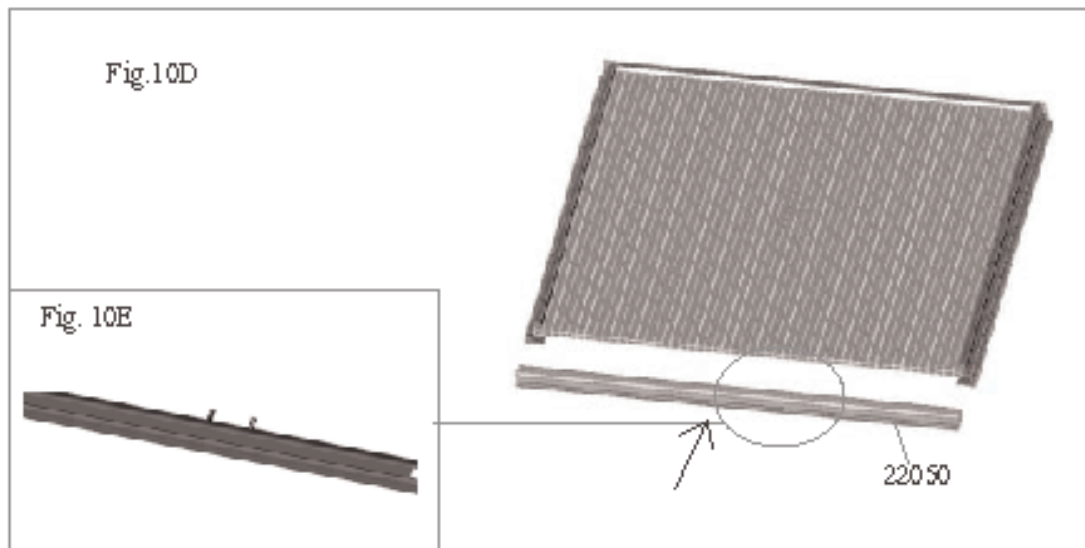

Fig. 10G

The door consists of two parts, an upper and a lower half. The door is fastened on the right, as viewed from outside.

Start the assembly with the lower half. To do this, take a bottom section 22080 and two side sections 22043, as with the vents, and screw them together to form a U-shaped structure. However, these sections are fastened with a hex-head screw and a nut each (see Fig. 11A). Then slide in the double-glazed pane 369.545.6 (6 mm), #369.555.6 (10 mm), 369.565.6 (16 mm), or 15059 (4mm THG) for glass, insert easyglaze strip 00411 in lower door section to protect edge of glass, if using glass follow foam insertion from fig 10G. Now close off the U structure at the bottom with section 22080 (see Fig. 11B). Here too, for a 6-mm pane slide rubber sections 22562, and for a 10-mm pane sections 22563, from the outside between the aluminium section and the double-glazed pane on the right and left, in order to compensate for the thickness of the pane (Fig. 11C).

Fasten the two hinges 22503 by screwing self-tapping screws 22530 (three each) into the pre-drilled holes in section 22043 (see Fig. 11D).

Do exactly the same for the upper half of the door, except for using side section 22042 on the side for the door bolt (on the left as viewed from outside) – see Fig. 13E.

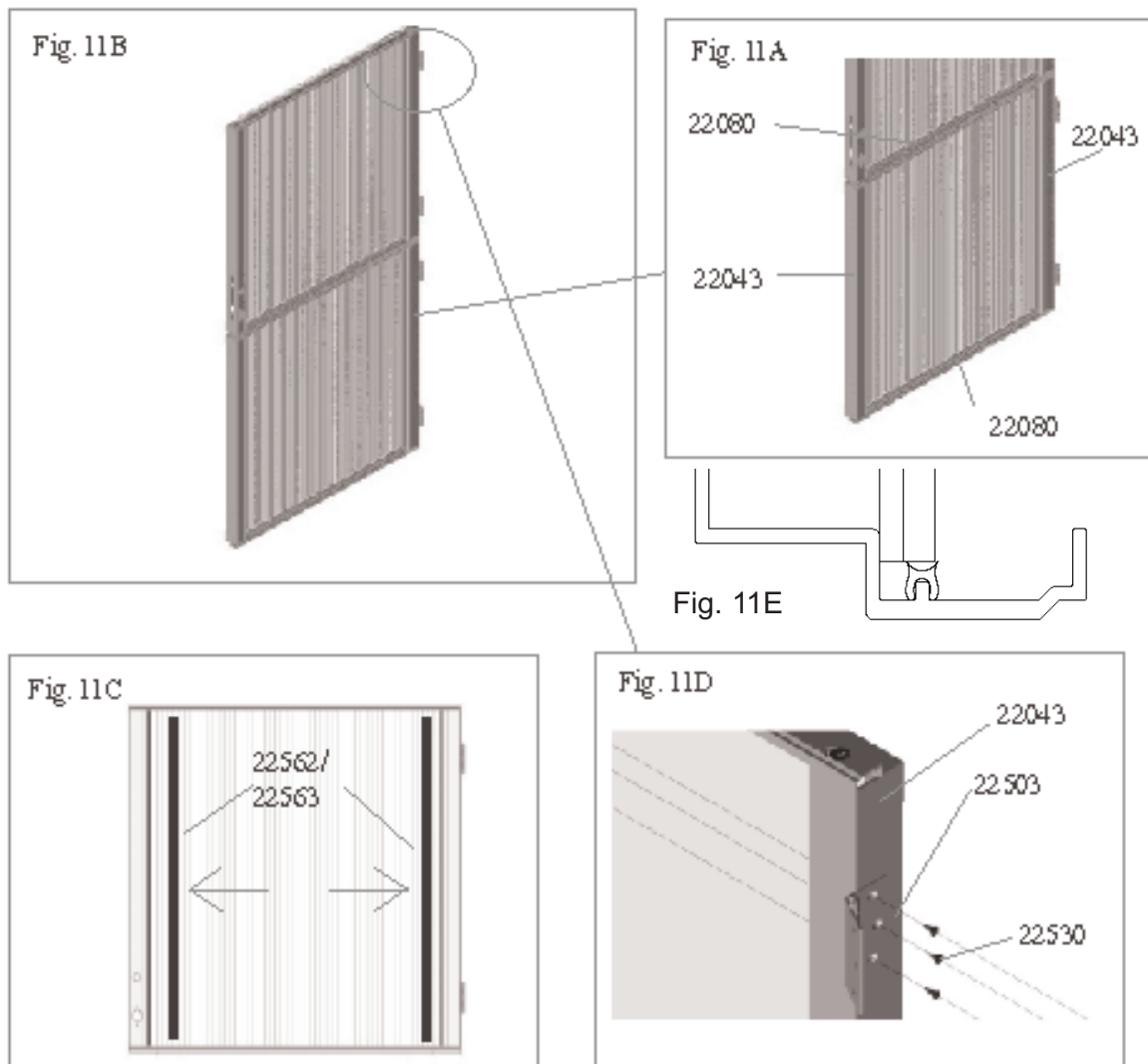

19 Assembly Step 11

(Doors 2)

Now take the assembled upper door frame and the cased frame lock 22537, and fasten it with screws 22597 (4.8 x 9.5 mm). Insert the lock cylinder 22539, and fix it in place with screw 22526 (5 x 30 mm). Then fasten the keyhole plate 22538 on the outside and the inside with two screws 22529 (4.8 x 13 mm) each.

Slide the door handles 22545 with the surrounds 22534 through the rectangular opening, and fix them in place with the cotter pin 22535 (see upright projection, Fig. 11F)

Complete door: Fig. 11G

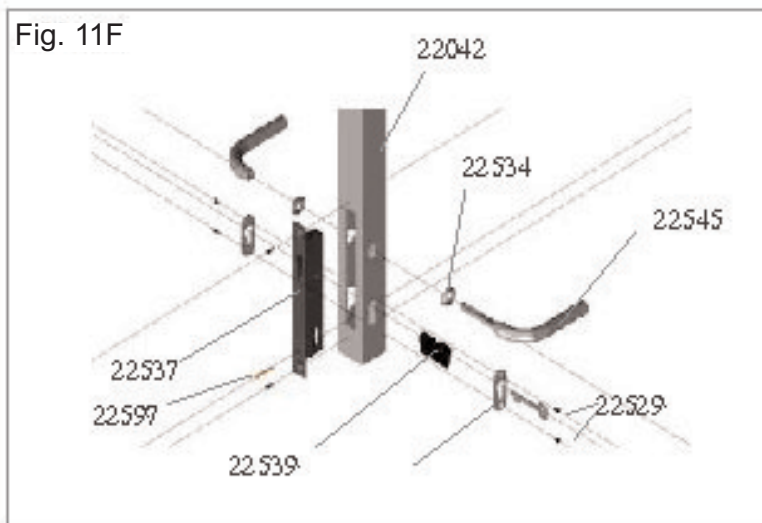

Fig. 11G



Set aside the doors for the moment.

Depending on the model and the thickness of the glazed panes, you will need different plans for this stage in assembly. Find the correct plan on the three following pages. Models 78 and 96 are shown in one box/view per thickness of the glazing (an oblique view, and the front, rear, roof, and side separately). All the panes for the side walls and the roof panes are placed in a U section – see Fig. 12A (not required for glass). The glazed panes are fastened on the left and right under a cover section. There are double cover sections (see Fig. 12B), which are fastened in the middle between two glazed panes, and single cover sections (see Fig. 12C), which are pressed into the corners and at the intermediate central sections, insert “O” Section 15061 into cover section as shown in Fig 12D. Which glazed panes and which cover sections or bottom sections belong where, you will see in the corresponding drawing (Fig. 12D, E or F) on the following pages.

Fig. 12A

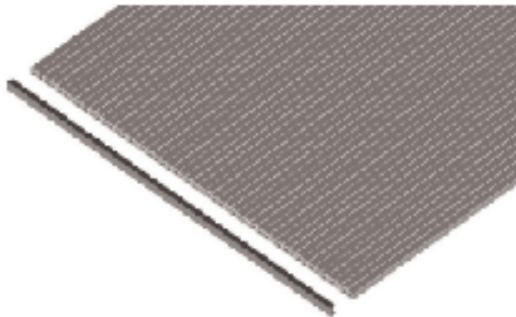

If the double-glazed panes are not parallel to the aluminium sections, check whether all the dimensions of the greenhouse are really at right angles.

Fig. 12B

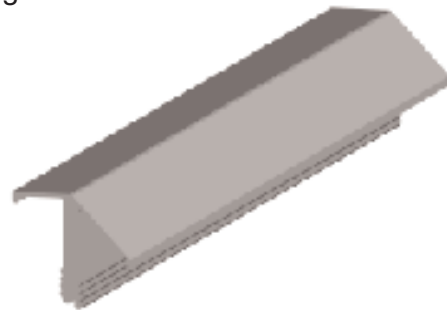

! If it becomes apparent that you will not be able to complete the greenhouse the same day, stop before glazing, and continue the next day! !

DO NOT LEAVE PART GLAZED

Fig. 12C

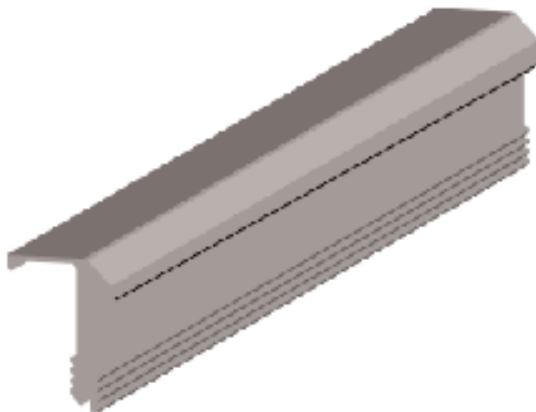

For this step in construction, you need a ladder and a rubber mallet (not included!).

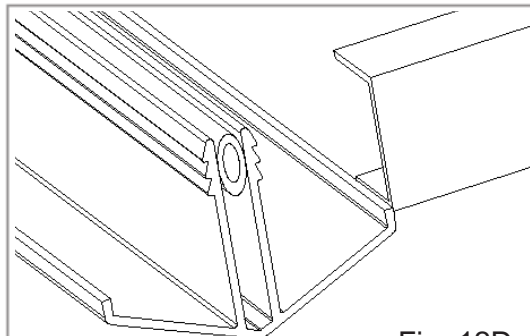
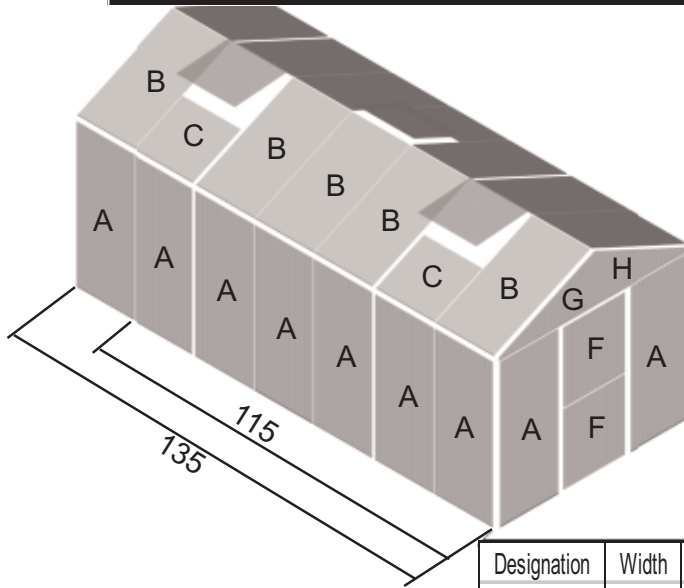

Fig. 12D

21 Assembly Step 12

(GLAZING, 6mm)



Plan of glazing panes

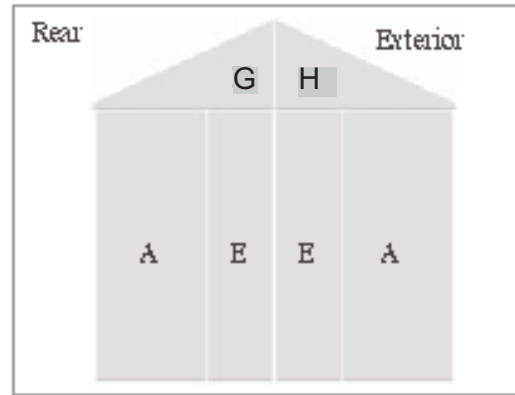

Slide all the U sections centrally only onto the bottoms of the double-glazed panes. The panes remain open at the top!

Designation	Width	Length	Height	Item No. 6mm	QTY	QTY	U Section
					115	135	
A	725	1792	-	15119	16	18	22591
B	725	1330	-	15118	9	11	22591
C	725	662	-	15120	3	3	22591
D	725	659	-	15120	3	3	22576
E	435	1792	-	15117	2	2	22588
F	765	873	-	15121	2	2	-
G	1190	595	40	15115	2	2	22578
H	1190	595	40	15116	2	2	22578

Plan of cover caps

Designation	Part No.	Length	QTY	QTY
			115	135
A	22564	1780	9	11
B	22585	1350	6	8
C	22566	570	2	2
D	22582	1350	16	16
G	22571	1780	18	18

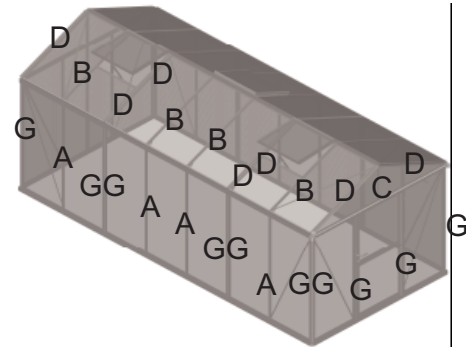

Rear Wall

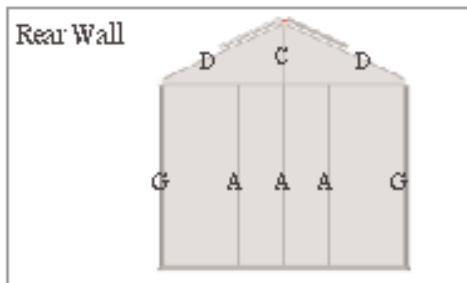

Use a rubber mallet to anchor the cover sections in the aluminium sections. Hammer gently, so as not to ruin the cover sections!

Be careful to centre the double-glazed panes in the window panels!

Assembly Step 12

(GLAZING, 10mm)

22

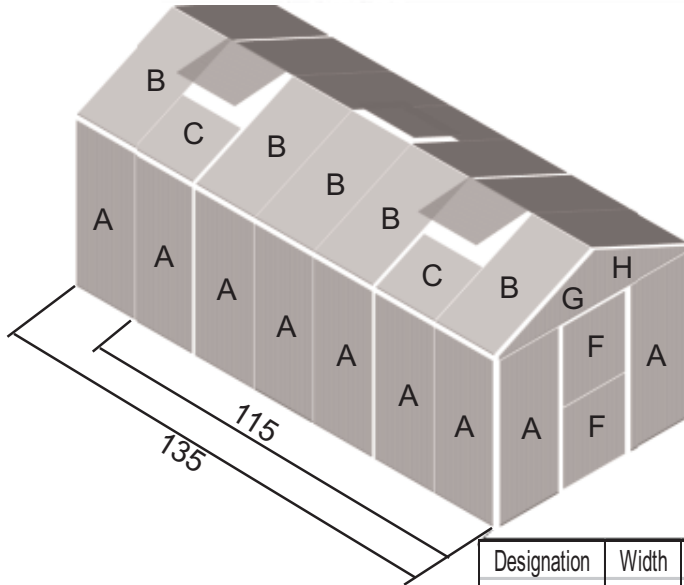

Plan of glazing panes

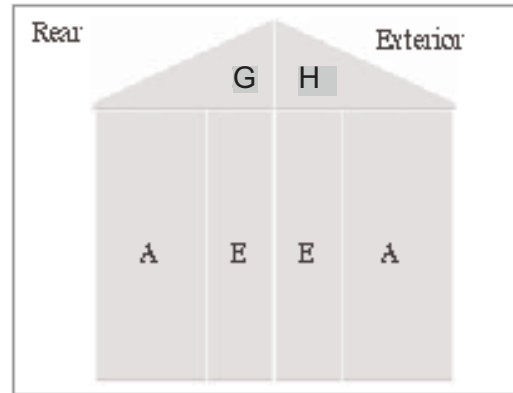

Slide all the U sections centrally only onto the bottoms of the double-glazed panes. The panes remain open at the top!

Designation	Width	Length	Height	Item No. 6mm	QTY 115	QTY 135	U Section
A	725	1792	-	15105	16	18	22592
B	725	1330	-	15104	9	11	22592
C	725	662	-	15106	3	3	22592
D	725	659	-	15106	3	3	22575
E	435	1792	-	15103	2	2	22589
F	765	873	-	15107	2	2	-
G	1190	595	40	15101	2	2	22579
H	1190	595	40	15102	2	2	22579

Plan of cover caps

Designation	Part No.	Length	QTY 115	QTY 135
A	22564	1780	9	11
B	22585	1350	6	8
C	22566	570	2	2
D	22582	1350	16	16
G	22571	1780	18	18

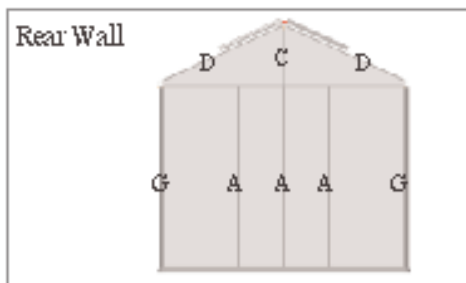
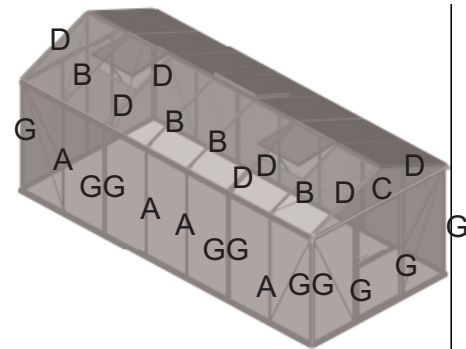

Use a rubber mallet to anchor the cover sections in the aluminium sections. Hammer gently, so as not to ruin the cover sections!

Be careful to centre the double-glazed panes in the window panels!

23 Assembly Step 12

(GLAZING, 16mm)

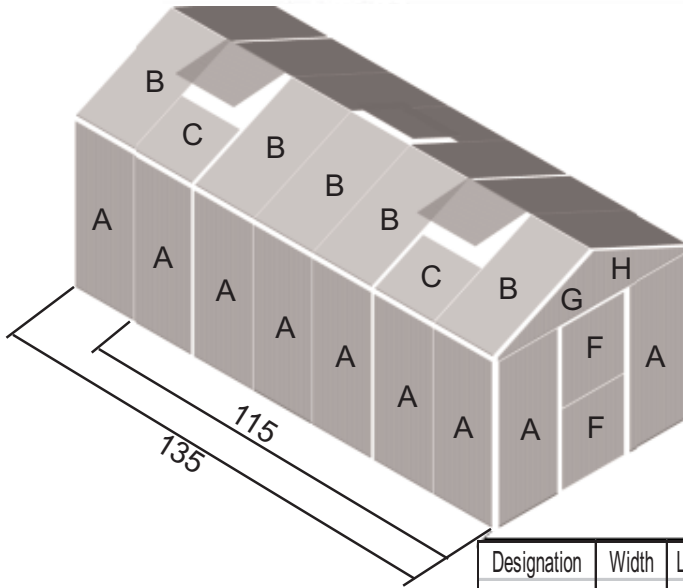

Plan of glazing panes

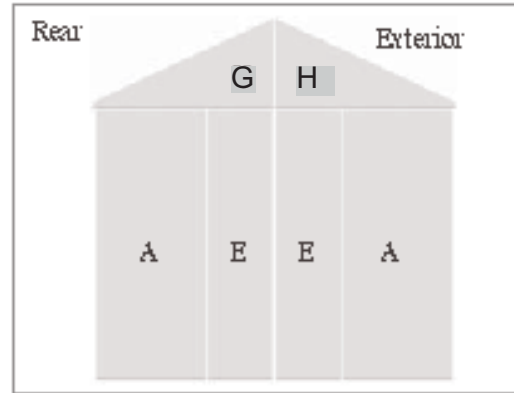

Slide all the U sections centrally only onto the bottoms of the double-glazed panes. The panes remain open at the top!

Designation	Width	Length	Height	Item No. 16mm	QTY 115	QTY 135	U Section
A	725	1792	-	15112	16	18	22593
B	725	1330	-	15111	9	11	22593
C	725	662	-	15113	3	3	22593
D	725	659	-	15113	3	3	-
E	435	1792	-	15110	2	2	22590
F	765	873	-	15114	2	2	22577
G	1190	595	40	15108	2	2	22581
H	1190	595	40	15109	2	2	22581

Plan of cover caps

Designation	Part No.	Length	QTY 115	QTY 135
A	22569	1780	9	11
B	22584	1350	6	8
C	22567	570	2	2
D	22583	1350	16	16
G	22573	1780	18	18

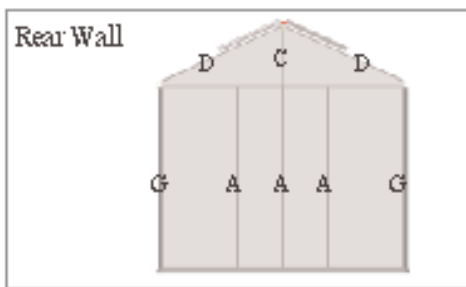
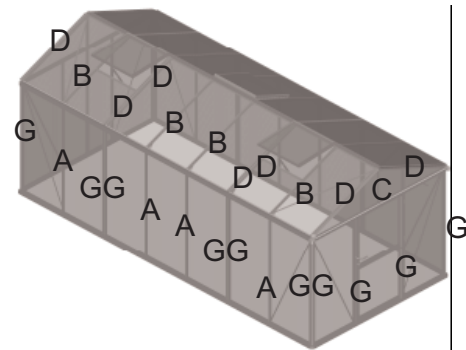

Use a rubber mallet to anchor the cover sections in the aluminium sections. Hammer gently, so as not to ruin the cover sections!

Be careful to centre the double-glazed panes in the window panels!

Assembly Step 12

(GLAZING, 4mm)

24

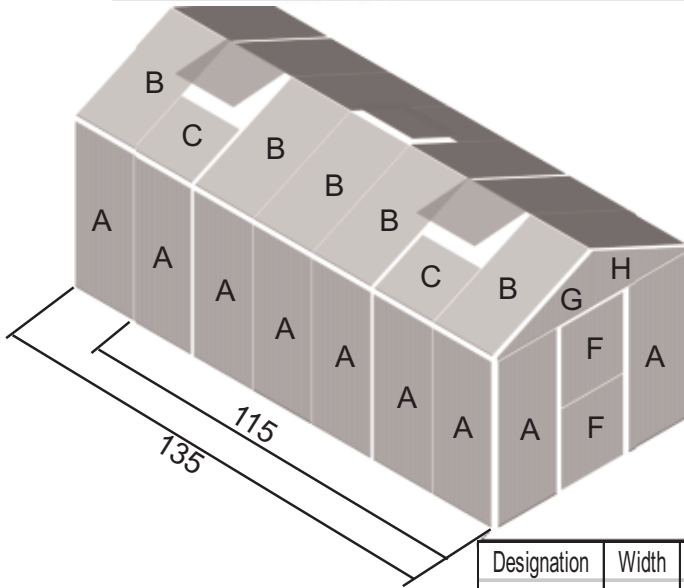

Plan of glazing panes

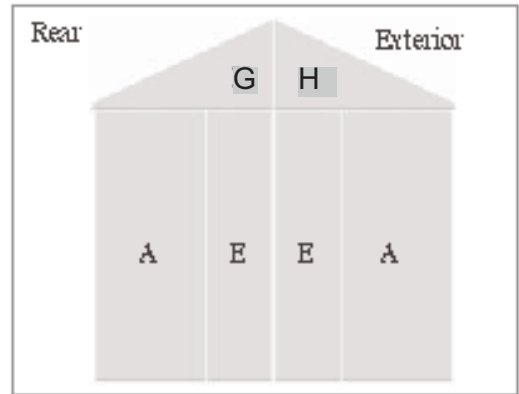

Designation	Width	Length	Height	Item No. 4mm	QTY	QTY	mm
					115	135	990
A	725	1792	-	15054	16	18	3584
B	725	1330	-	15055	9	11	2660
C	725	659	-	15056	3	3	1318
D	725	659	-	15056	3	3	1318
E	435	1792	-	15060	2	2	3584
F	765	873	-	15059	2	2	1746
G	1190	595	40	15058	2	2	1230
H	1190	595	40	15058	2	2	1230

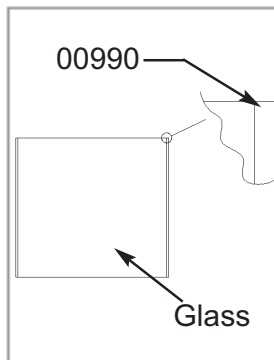

Plan of cover caps

Designation	Part No.	Length	QTY	QTY
			115	135
A	22564	1780	9	11
B	22585	1350	6	8
C	22566	570	2	2
D	22582	1350	16	16
G	22571	1780	18	18

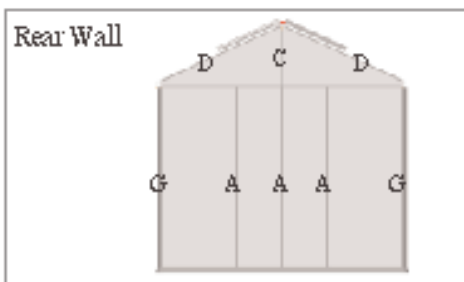
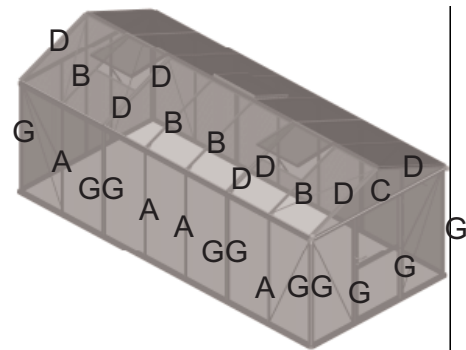

Use a rubber mallet to anchor the cover sections in the aluminium sections. Hammer gently, so as not to ruin the cover sections!

Be careful to centre the double-glazed panes in the window panels!

25 Assembly Step 13

(Installing Doors)

The framing of the greenhouse has been erected, and the glazing is also completed. It only remains to install the doors and vents (Fig. 13A).

Take the two pre-assembled door halves, and screw them to the right-hand jamb post 22090 (as viewed from the outside). Use the self-tapping screws (three per hinge), parts number 22528, to fasten the door halves as shown in Fig. 13B.

Fasten the rebate strip 22154 to the outside of the lower half of the door with four screws 22597 (see Fig. 13B). Then take door bolt 22536, and fasten it with two screws 22530, as shown in Fig. 13C.

Fig. 13A

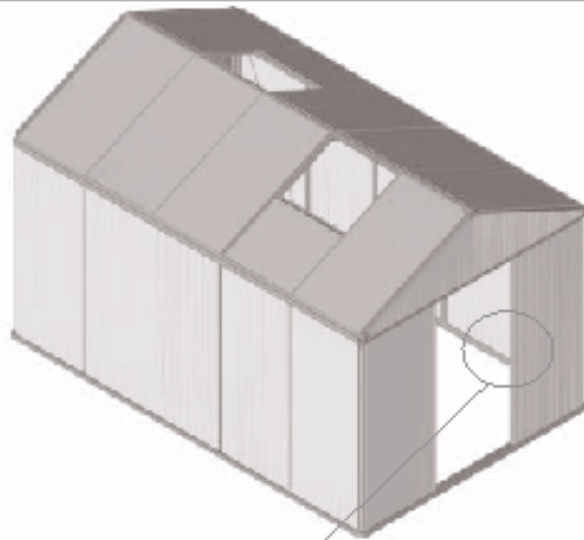
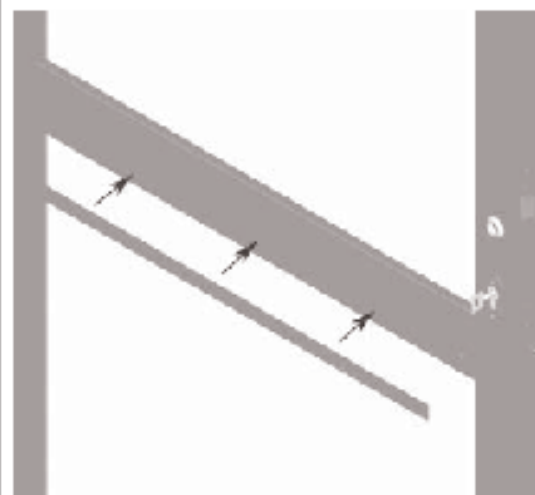

Fig. 13B



Fig. 13C



Assembly Step 13

(Installing Doors (2))

26

Then take the door connecting latch 22594, and fasten it to the upper half of the door with screws 22598. Take two screws, parts number 22598, and fasten them as shown in Fig. 13D, one in the upper profile section as a rest for when the door halves are not fastened together, and one in the lower section as a stop when they are.

Note. There are no pre-drilled holes for installing the connecting latch. Use a 2-mm metal-drilling drill point, and drill holes for the self-tapping screws 22598 about 25 cm from the edge of the door (lock side). First drill the hole for the connecting latch, and then for the other two screws, using the connecting latch to determine the distance.

As the last step in installing the doors, fasten door stop 22541 with two 6 x 12 mm hexagon-head screws 22524 (slide them into 22120 from the side), as shown in Fig. 13E. The stop must be able to reach over the top door section from above. To release it, the front edge is lifted a little.

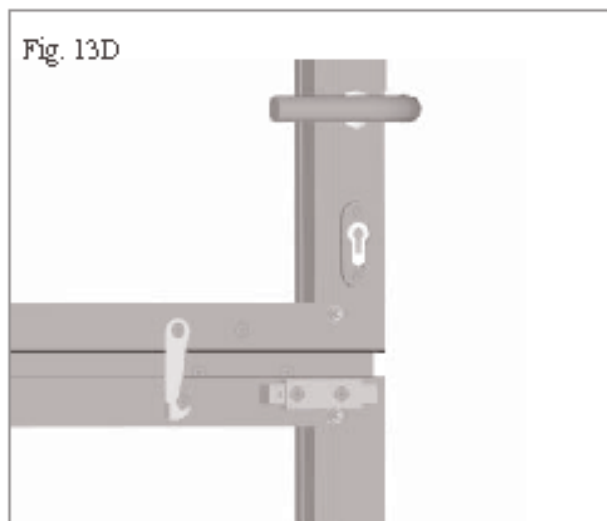

Fig. 13F

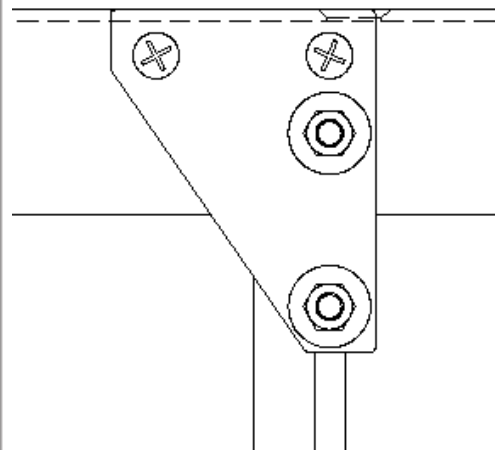
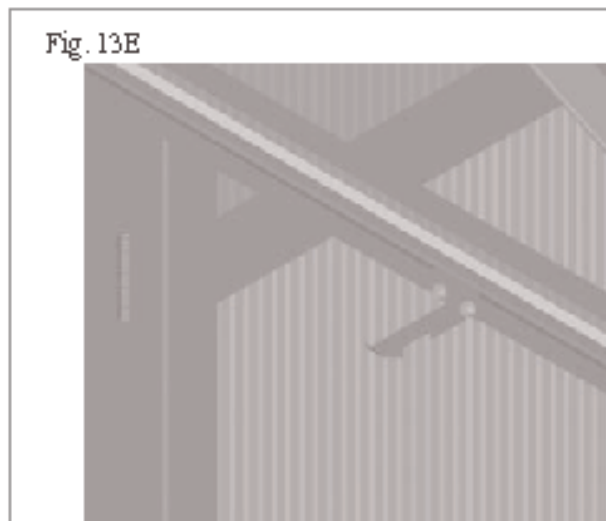

Fig. 13E



27 Assembly Step 14

(Installing Vents)

Go inside the greenhouse, and fasten the vent peg and plate 15132 and 00450 to the vent fastening section (window-sill) by the loose screws of Step 10, as shown in Fig. 14A.

Now slide the prepared roof vent, as shown in Fig. 14B onto the roof ridge to the segment/panel where you intend to install it.

Do the same thing with the second roof vent.

Then fasten the vent stay as shown below.

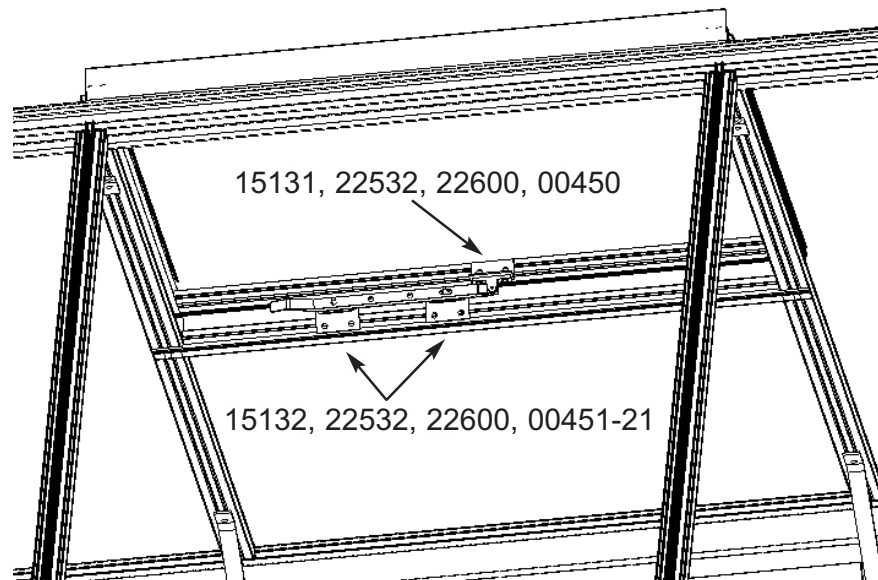

Now place the plastic ridge and gutter coverings at hand. The ridge caps 22523 must be fastened with two self-tapping screws 22598 (4.2 x 13 mm), as shown in Fig. 15A. Since there are no pre-drilled holes, use a power drill and a 2-mm drill point to start the holes. Use cap 22523 as a template.

The right (22521) and left (22522) gutter caps are different. Simply push them onto the gutter (see Fig. 15B). At the position where you wish to mount the downpipe, you must open the round hole marked out. Use something like a hammer handle that fits through the opening, and knock it out.

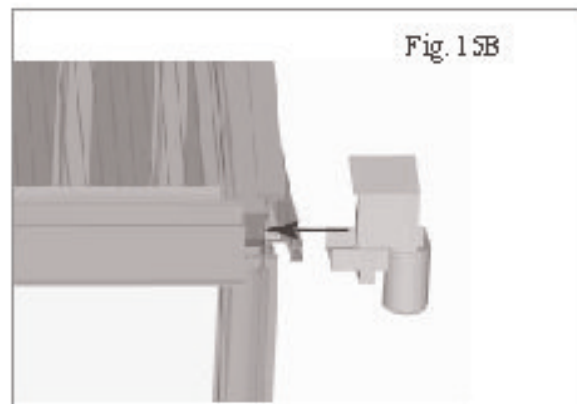
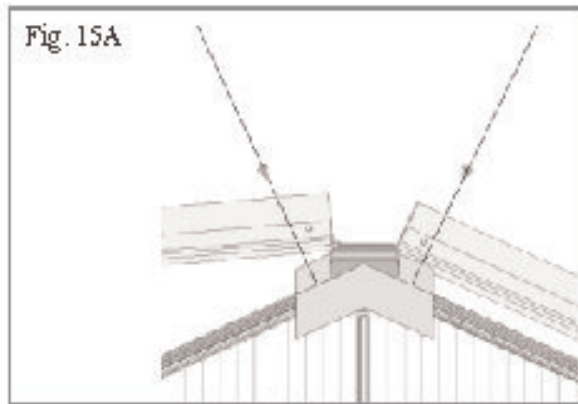

The assembly of the greenhouse is now completed.

We wish you luck in growing your plants!