

Installation Instructions

for Using HCP Fastening Accessories

BRINGS NATURE IN

Wise men look before they leap...

This ancient adage is certainly very apt in the case of long life construction elements such as air vents; shade roofing, covered car parking, greenhouses, warehouses, interior partitions, skylights and more...

These installation instructions will allow you to install Polycarbonate sheets correctly.



Safety at the Jobsite

- ✓ Employ all safety measures required for working on scaffolding and roofs
- ✓ Beware of slipping when working above the roofing sheets
- ✓ Beware of losing your balance when carrying sheets in windy conditions

A selection of Polygal products:

Product	Thickness (mm)	Colors	Dimensions
PCSS Type Sheets	6, 8, 10, 16	Clear, bronze, and ice.	Standard Dimensions: Width – 2.1 m. Length – 6 m. Special Dimensions: Width – Any width up to 2.1 m. Length – Up to 20 m.
Titan Type Sheets	16		
HCP Polycarbonate Fastenings		Clear	Standard Dimensions: Length – 6 m. Special Dimensions: Length – Up to 20 m.

Storage Before Installation

- Store the sheets on a flat surface, protected from direct sunlight.
- Do not cover the roofing sheets with PVC sheeting (tarpaulin).

Preparing the Supporting Structure

- Complete all the metalwork and painting before beginning sheet installation work.
- Check the dimensions on site, and plan the roofing requirements before ordering products for the project.

Planning the Supporting Structure

- Install the sheets with the ribs parallel to rain flow and with a slope of at least 10° ①
- Supporting beams must be at least 30 mm wide ② to ensure good anchorage of sheets and fastening accessories.

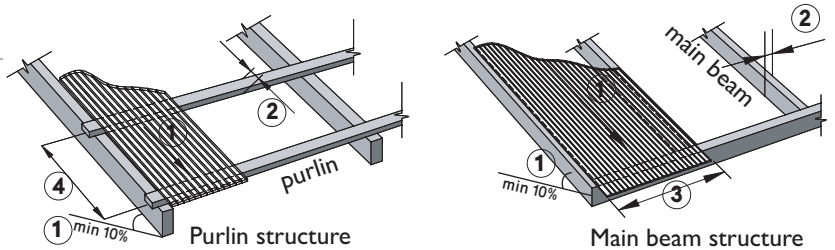

Calculation of maximum recommended* distance between main beams and between purlins for **flat roofing** must take into account wind pressure of up to 100 kg².

Sheet Type and Thickness (mm)	Distance (cm) Between Supporting Structure Main Beams (sheet width)	Distance Between Purlins According to Sheet Width		
		Up to 70 cm	Up to 100 cm	Up to 125 cm
Standard 8 – 10	75	120	115	90
Standard 16 / Titan 16	105 / 120	150	125	120

Calculation of maximum recommended* distance between main beams and between purlins for **curved roofing** must take into account wind pressure of up to 100 kg².

Sheet Type and Thickness (mm)	Curve width S (cm)	Curve height h (cm)	Distance between main beams (sheet width) in the main beam structure (cm)						Distance between purlins for a 125 cm wide sheet			
			300			400				500		
			45 - 75	60	80	100	75	100		125		
Standard 8 – 10	125	125	95	115	125	80	95	105	110			
Standard 16 / Titan 16	125	-	125	-	125	-	125	-	120			

* Ensure that a qualified professional checks and approves the structure before execution.

Smallest permissible cold bending radius (R)

Sheet Thickness (mm)	6	8	10	16
Smallest Bending Radius (m)	1.05	1.40	1.75	2.80

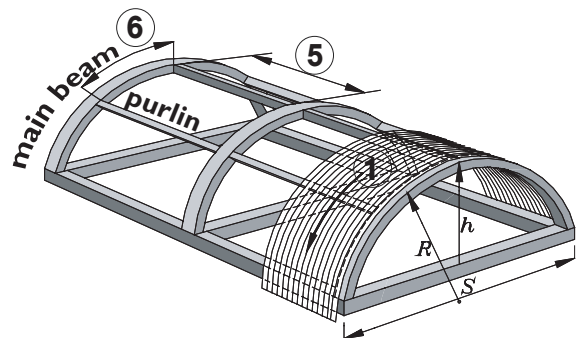

Accessories Required for Installation

Accessory	Image	Accessory Catalogue Number			
		6 mm Sheet	8 mm Sheet	10 mm Sheet	16 mm Sheet
Aluminum Edge Profile		327	311	312	313
Polycarbonate Connecting Profile		210			211
Polycarbonate Base Profile		207			
Side Spacer Profile		226			313
Base Profile Anchoring Screw (1 1/4")		412 (metal structures) 421 (wood structures)			
Sheet Anchoring Screw (2")		400 (metal structures) 422 (wood structures)			
Bell Seal		473			
Anchor profile cap to connecting profile		424			
Ventilating Edge Tape		508		509	
Sealed Edge Tape		512		513	

Preparing the Sheets

- Remove the grey protective film (2).
- Fold back the printed sheet protection film 10 cm on each side (3).
- Attach ventilating edge tape (4a) to the lower edge and sealed edge tape (4b) to the upper edge.

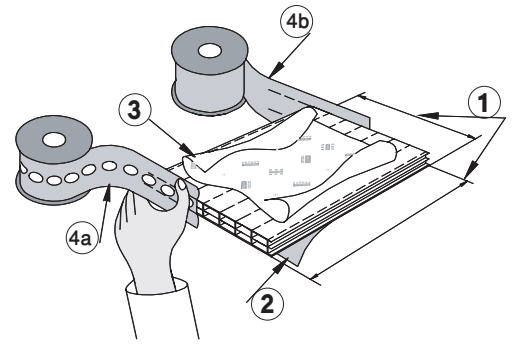

Preparing the End Profiles

- Use a metal saw to cut the aluminum edge profiles (see: Accessories Table) into pieces matching the width of sheets to which they will be attached.
- Drill drainage channels to allow for the flow of condensed water along the profiles used for the bottom section of the building's roof.
- Attach the edge profile to the sheet with the short side on top of the sheet.

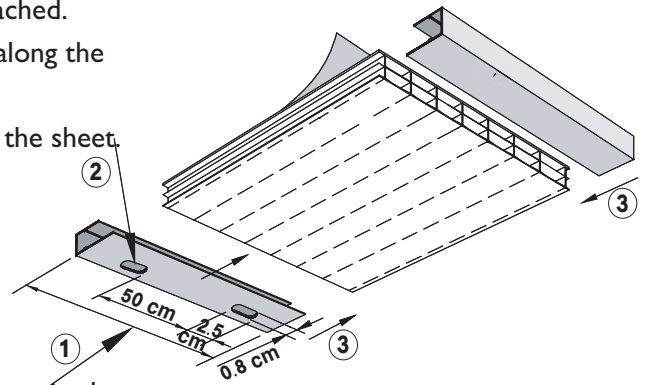

Preparing the HCP Connecting Profiles

- Cut the base profile (207) and the cap (210 or 211) to the length required. For curved roof buildings, cut the connecting profile cap 2 cm longer than the base.
- To anchor to non-metal structures, drill 7 mm holes, 50 cm apart in the base for the beam structure or according to the position of the purlins.

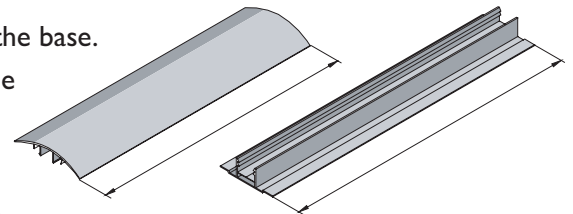

Installation Instructions for Roofing a Beamed Structure

Step 1 – Use screws (see: Accessories Table) to attach the base connecting profiles to the roof beams. Make sure that screws do not bend, tear or exert excessive pressure on the profile.

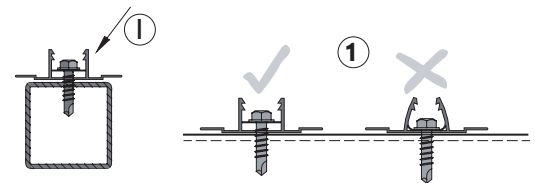

Step 2 – Place the sheet on top of the base profile support edges, with the side covered by the printed protective film facing upwards.

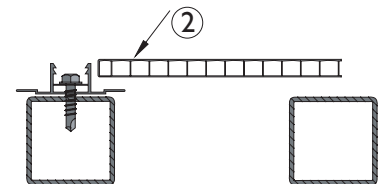

Step 3 – Slide the base under the sheet and attach it to the beam.

Step 4 – Place the side spacer profile (see: Accessories Table) onto the roof beam and attach the cap to the base by hammering into place with a rubber mallet.

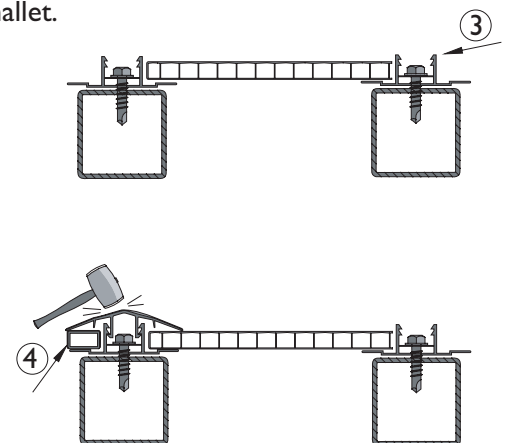

Steps 5 to 7 – Continue adding sequentially, a sheet (step 5), a base connecting profile (step 6) and a cap (step 7) until reaching the end of the building. After completing installation, remove all the printed protective film from the sheets.

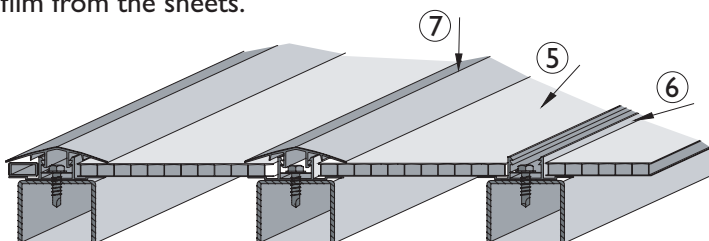

Installation Instructions for Roofing a Purlin Structure Building

Step 1 – Place the sheets with the side protected by the printed film upwards, ensuring that they are at a right angle from the building's top roofline.

Step 2 – Slide the base connecting profile underneath the sheet edge and use base profile attaching screws (see: Accessories Table) to anchor them to the purlins. Make sure that the screw does not tear, bend or exert excessive pressure on the base connecting profile.

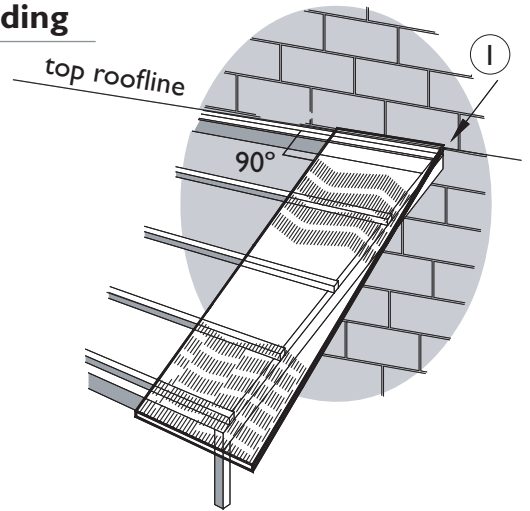
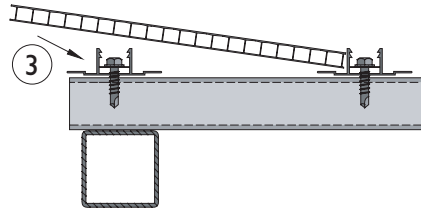
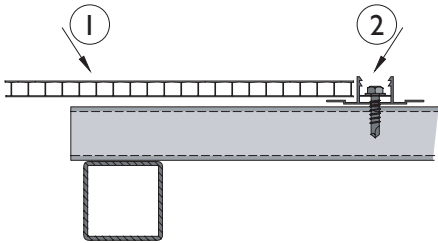

Step 3 – Attach the base to the roofline purlins.

Step 4 – Match sheet size to the distance between the bases.

Step 5 – Position the side spacer profile in place (see: Accessories Table – for 6 mm thick sheets, use a 3 cm wide piece of sheet as the side spacer). Position the connecting profile cap in place and, with a shock-absorbing support under the sheet, use a rubber mallet to connect it to the base.

Steps 6 and 7 – Continue to add sheets, (step 6) and caps (step 7) until reaching the end of the building. After completing installation, remove all the printed protective film from the sheets.

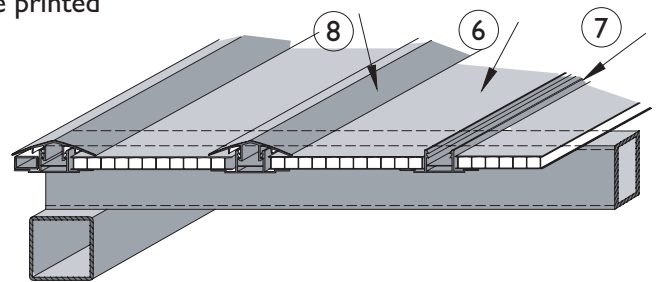
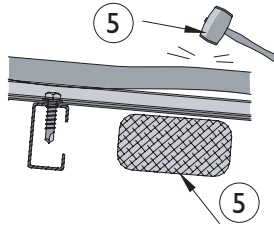
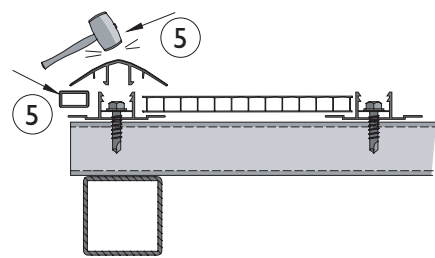
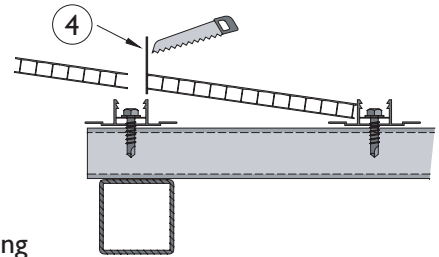

Attaching to Walls, Gutters and Ridges

- Form the metal cladding parts which will be attached to the wall on one side and will cover the sheet edge on the other side ①. Seal with Silicone as needed.
- Plan a gutter with a receptacle area and connect the sheet to the gutter ②.
- Form the metal cladding part for the roofline and connect it to the caps.

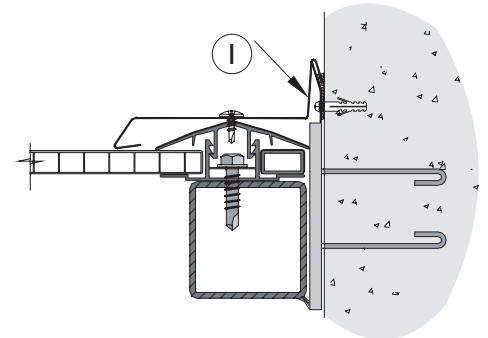

Finish and Fixing Reinforcements

- Place fixing screws with seals only in the support frame lines ③.
- Do not over-tighten screws.

HCP-install-eng-0606-01

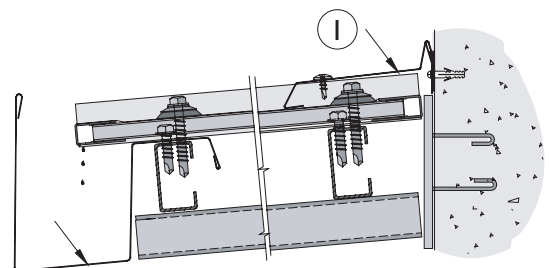
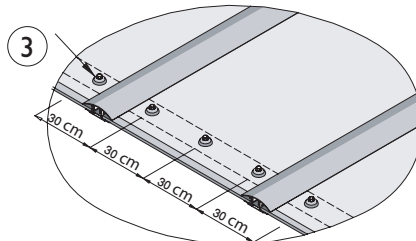
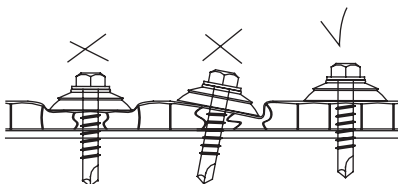

The information provided in this publication is given freely and constitutes general information that does not grant or imply any warranty. Polycarbonate is a thermoplastic material that can withstand fire in accordance with different international standards and as applicable in each different country. Do not expose to high levels of heat or to aromatic cleaning materials. In each different structure, the appropriate safety measures must be implemented in accordance with the fire prevention instructions provided by the fire safety authorities.